



# BRICS

# TRANSPORT

International science and practice journal



Volume 4  
Issue 3

# 2025

ISSN 2949-0812 (ONLINE)  
DOI 10.46684/2025.3  
WWW.BRICSTRANSPORT.RU

# BRICS Transport

SCIENTIFIC AND PRACTICAL PEER-REVIEWED JOURNAL

*Founded in 2022*

*Publication frequency: 4 issues per year*

**Volume 4**

**Issue 3**

**2025**

# Транспорт БРИКС

НАУЧНО-ПРАКТИЧЕСКИЙ РЕЦЕНЗИРУЕМЫЙ СЕТЕВОЙ ЖУРНАЛ

*Основан в 2022 году*

*Выходит ежеквартально*

*Сквозной номер 12*

**Том 4**

**Выпуск 3**

**2025**

# BRICS Transport

## SCIENTIFIC AND PRACTICAL PEER-REVIEWED JOURNAL

Journal's main thematic focus: scientific, technical, organizational, economic, environmental, legal issues, history, current state and development prospects of the BRICS countries' transport complex; interaction of the BRICS countries on issues of transport support and international cooperation, global transport systems, as well as on professional education for the transport industry and development of cooperation between educational institutions and transport enterprises from different countries.

*This is an open access journal.*

### SECTION POLICIES

- TRANSPORT ECOSYSTEM: SOCIETY, STATE, AND GLOBAL CHALLENGES
- URBAN STUDIES, TRANSPORT AND LOGISTICS TECHNOLOGIES
- VEHICLES AND ROLLING STOCK
- TRANSPORT INFRASTRUCTURE
- ADVANCED ENGINEERING TRAINING FOR THE ECONOMY 4.0
- SMART TRANSPORT AND INTELLIGENT SYSTEMS FOR THE INDUSTRY 4.0
- ECONOMICS OF INTERNATIONAL TRANSPORT AND LOGISTICS: INTELLIGENT AND DIGITAL SOLUTIONS AND PRACTICES
- TRANSPORT HISTORY
- MISCELLANEA

Digital version registration certificate:  
El. No. ΦС77-82614 dated January 27, 2022.  
Website journal: bricstransport.ru  
E-mail: brics@umczdt.ru  
Tel.: +7(495)739-00-30. add. 134  
105082, Russia, Moscow, 71 Bakuninskaya st.

### FOUNDERS

- Federal State Budgetary Educational Institution of Higher Education "Emperor Alexander I St. Petersburg State Transport University", 9 Moskovsky pr., St. Petersburg, 190031, Russian Federation
- Federal state budget establishment additional professional education "Educational and instructional center for railway transportation", 71 Bakuninskaya st., Moscow, 105082, Russian Federation

### PUBLISHER

- Federal state budget establishment additional professional education "Educational and instructional center for railway transportation"

### EDITORIAL STAFF OF A JOURNAL

*Managing editor*  
Lidiya A. Shitova

*The translation was done by A2Z  
Translation Agency (A2Z Translation Agency)*

*Logo design, journal cover and website design*  
by Igor Kiselev and Sergey Turin

*Design and layout*  
LLC "Advanced Solutions", www.aov.ru

Signed for printing 17.09.2025.

### EDITORIAL BOARD

#### Editorial board chairman

- *Oleg S. Valinsky*, Cand. Sci. (Tech.), rector; Emperor Alexander I St. Petersburg State Transport University; St. Petersburg, Russia

#### Editor-in-chief

- *Irina Skovorodina*, Ph.D. in History; Training and Methodological Centre on Education on Railway Transport; Moscow, Russia; editor@umczdt.ru

#### Chief science editor

- *Igor Kiselev*, Railway Engineer, Sc.D. in History, Honorary Professor of Emperor Alexander I St. Petersburg State Transport University; Saint-Petersburg, Russia; transportbrics@pgups.ru

#### Members of the editorial board

- *Anatoly Aleksandrov*, Sc.D. in Engineering, President of Bauman Moscow State Technical University, Professor; Moscow, Russia
- *Manoj Choudhary*, Dr., Prof., Vice Chancellor of a Central University sponsored by the Ministry of Railways, Govt. of India (Shakti Vishwavidyalaya Lalbaug), Vadodara (Gujarat), India
- *Boris Eliseev*, Sc.D. in Law, Professor, Rector of Moscow State Technical University of Civil Aviation; Moscow, Russia
- *Vladimir Kolesnikov*, Academician of the Russian Academy of Sciences, Chairman of the Council of the Russian Academy of Sciences on Innovative Problems of Transport and Logistics at the Presidium of the Russian Academy of Sciences; Moscow, Russia
- *Vladimir Okrepilov*, Doctor of Economics, Scientific Director of the Institute of Regional Economics of the Russian Academy of Sciences; President of the Metrological Academy (Interregional Public Organization) Academician of the Russian Academy of Sciences, Saint-Petersburg, Russia
- *Wang Shuguo*, Sc.D., President (Rector) of Xi'an Jiaotong University (Xi'an University of Transport), Professor; Xi'an, China
- *Richard Magdalena Stephan*, Dr., full professor of the National University of Rio de Janeiro, Head of Engineering Center; Rio de Janeiro, Brazil
- *Viktor Ushakov*, Sc.D. in Engineering, Head of the Department of Road Construction and Operation, Moscow Automobile and Road Construction State Technical University; Moscow, Russia
- *Vladimir Vereskun*, Sc.D. in Engineering, Rector of Rostov State Transport University, Professor; Rostov-on-Don, Russia
- *Jabbar Ali Zakeri*, Doctor of Philosophy in Civil engineering – road and railroad engineering, Chancellor of Iran University of Science & Technology, Professor of School of Railway Engineering of Iran University of Science & Technology; Iran, Tehran

© Federal State Budgetary Educational Institution of Higher Education "Emperor Alexander I St. Petersburg State Transport University", 2025

© Federal state budget establishment additional professional education "Educational and instructional center for railway transportation", 2025

# Транспорт БРИКС

## НАУЧНО-ПРАКТИЧЕСКИЙ РЕЦЕНЗИРУЕМЫЙ СЕТЕВОЙ ЖУРНАЛ

Основная тематическая направленность журнала: материалы о научно-технических, организационных, экономических, экологических, правовых проблемах, истории, состоянии и перспективах развития транспортного комплекса стран БРИКС; о взаимодействии стран БРИКС по вопросам транспортного обеспечения и сотрудничества с другими государствами, мировыми транспортными системами, а также о подготовке персонала всех уровней для транспортной отрасли и развитии в данной сфере сотрудничества образовательных учреждений и транспортных предприятий разных стран.

Статьи журнала находятся в открытом доступе.

### РАЗДЕЛЫ ЖУРНАЛА

- ЭКОСИСТЕМА ТРАНСПОРТА: ОБЩЕСТВО, ГОСУДАРСТВО И ГЛОБАЛЬНЫЕ ВЫЗОВЫ
- УРБАНИСТИКА, ТРАНСПОРТНЫЕ И ЛОГИСТИЧЕСКИЕ ТЕХНОЛОГИИ
- ТРАНСПОРТНЫЕ СРЕДСТВА И ПОДВИЖНОЙ СОСТАВ
- ИНФРАСТРУКТУРА ТРАНСПОРТА
- ОПЕРЕЖАЮЩАЯ ПОДГОТОВКА ИНЖЕНЕРНЫХ КАДРОВ ДЛЯ ЭКОНОМИКИ 4.0
- УМНЫЙ ТРАНСПОРТ И ИНТЕЛЛЕКТУАЛЬНЫЕ СИСТЕМЫ ДЛЯ ИНДУСТРИИ 4.0
- ЭКОНОМИКА МЕЖДУНАРОДНЫХ ПЕРЕВОЗОК И ЛОГИСТИКИ: ИНТЕЛЛЕКТУАЛЬНЫЕ И ЦИФРОВЫЕ РЕШЕНИЯ И ПРАКТИКА
- ИСТОРИЯ ТРАНСПОРТА
- РАЗНОЕ

Свидетельство о регистрации электронной версии: Эл №ФС77-82614 от 27 января 2022 г.

Сайт журнала: [bricstransport.ru](http://bricstransport.ru)

E-mail: [brics@umczdt.ru](mailto:brics@umczdt.ru)

Тел.: +7(495)739-00-30. Доб. 134

105082, Россия, г. Москва, ул. Бакунинская, д. 71

### УЧРЕДИТЕЛИ

- ФГБОУ ВО «Петербургский государственный университет путей сообщения Императора Александра I»
- ФГБУ ДПО «Учебно-методический центр по образованию на железнодорожном транспорте»

### ИЗДАТЕЛЬ

- ФГБУ ДПО «Учебно-методический центр по образованию на железнодорожном транспорте»

### РЕДАКЦИЯ ЖУРНАЛА

Ответственный редактор

Лидия Александровна Шитова

Перевод ООО «Центральное бюро переводов «Знание» (A2Z Translation Agency)

Дизайн логотипа, обложки и оформления сайта

журнала — Игорь Киселёв и Сергей Тюрин

Дизайн и верстка ООО «Адвансед солюшнз», [www.aov.ru](http://www.aov.ru)

Подписано в печать 17.09.2025.

© ФГБОУ ВО «Петербургский государственный университет путей сообщения Императора Александра I», 2025

© ФГБУ ДПО «Учебно-методический центр по образованию на железнодорожном транспорте», 2025

### РЕДАКЦИОННАЯ КОЛЛЕГИЯ

#### Председатель редакционной коллегии

- Олег Сергеевич Валинский, канд. техн. наук, ректор; Петербургский государственный университет путей сообщения Императора Александра I (ПГУПС); Санкт-Петербург, Россия

#### Главный редактор

- Ирина Сергеевна Сквородина, кандидат исторических наук, Учебно-методический центр по образованию на железнодорожном транспорте; Москва, Россия; [editor@umczdt.ru](mailto:editor@umczdt.ru)

#### Главный научный редактор

- Игорь Павлович Киселёв, инженер путей сообщения, доктор исторических наук, почетный профессор Петербургского государственного университета путей сообщения Императора Александра I; Санкт-Петербург, Россия; [transportbrics@pgups.ru](mailto:transportbrics@pgups.ru)

#### Члены редакционной коллегии

- Анатолий Александрович Александров, доктор технических наук, президент Московского государственного технического университета им. Н.Э. Баумана, профессор; Москва, Россия
- Владимир Дмитриевич Верескун, доктор технических наук, ректор Ростовского государственного университета путей сообщения, профессор, Ростов-на-Дону, Россия
- Борис Петрович Елисеев, доктор юридических наук, профессор, ректор Московского государственного технического университета гражданской авиации; Москва, Россия
- Джаббар Али Закеи, доктор наук в области гражданского строительства, ректор Иранского университета науки и технологии, профессор Школы железнодорожных инженеров Иранского университета науки и технологии; Иран, Тегеран
- Владимир Иванович Колесников, академик РАН, председатель Совета РАН по инновационным проблемам транспорта и логистики при президиуме РАН; Москва, Россия
- Владимир Валентинович Окрепилов, доктор экономических наук, научный руководитель Института проблем региональной экономики РАН; президент Метрологической академии (Межрегиональная общественная организация); академик РАН; Санкт-Петербург, Россия
- Рихард Магдалена Стефан, доктор наук, профессор кафедры электротехники Национального университета Рио-де-Жанейро, председатель Бразильского общества силовой электроники; Рио-Де-Жанейро, Бразилия
- Виктор Васильевич Ушаков, доктор технических наук, заведующий кафедрой «Строительство и эксплуатация дорог» Московского автомобильно-дорожного технического университета; Москва, Россия
- Манодж Чудхари, доктор наук, профессор, проректор Центрального университета Министерства железных дорог Индии, Ваходара (Гуджарат), Индия
- Ван Шуго, доктор наук, ректор Сианьского университета Цзяотун (Сианьского транспортного университета), профессор; Сиань, Китай

# CONTENT

## MISCELLANEA

From the first public railway to high-speed rail transport. The 200th anniversary of the Stockton and Darlington Railway, England, and the 12th World Congress on High-Speed Rail 2025 in Beijing

*Igor P. Kiselev*

## TRANSPORT ECOSYSTEM: SOCIETY, STATE, AND GLOBAL CHALLENGES

Engineering of an electric train for the first phase of the high-speed railway network in Russia

*Vladimir E. Andreev*

## VEHICLES AND ROLLING STOCK

Development of an improved design of a high-capacity passenger railcar for the railways of Uzbekistan

*Rustam V. Rahimov, Farida S. Galimova, Diyor Sh. Zafarov*

## ENGINEERING TRAINING FOR THE ECONOMY 4.0

Major aspects of interaction between Russian and Chinese educational institutions for the benefit of sectoral economy

*Maksim A. Garanin, Zeng Qingjun*

## ECONOMICS OF INTERNATIONAL TRANSPORT AND LOGISTICS: INTELLIGENT AND DIGITAL SOLUTIONS AND PRACTICES

Shipbuilding industry of Russia: State and problems of strategic development

*Nataliya E. Tereshkina, Olga A. Khalturina*

## TRANSPORT HISTORY

High-speed railway. Effect of previous successful designers

*Igor P. Kiselev*

# СОДЕРЖАНИЕ

## РАЗНОЕ

От первой железной дороги общего пользования к высокоскоростному железнодорожному транспорту. 200 лет железной дороги «Стоктон и Дарлингтон», Англия и 12-й Всемирный конгресс по высокоскоростным железным дорогам 2025 г. в Пекине

*И.П. Киселев*

## ЭКОСИСТЕМА ТРАНСПОРТА: ОБЩЕСТВО, ГОСУДАРСТВО И ГЛОБАЛЬНЫЕ ВЫЗОВЫ

Разработка электропоезда для первого этапа сети высокоскоростных магистралей в России

*В.Е. Андреев*

## ТРАНСПОРТНЫЕ СРЕДСТВА И ПОДВИЖНОЙ СОСТАВ

Разработка усовершенствованной конструкции пассажирского вагона увеличенной вместимости для железных дорог Узбекистана

*Р.В. Рахимов, Ф.С. Галимова, Д.Ш. Зафаров*

## ОПЕРЕЖАЮЩАЯ ПОДГОТОВКА ИНЖЕНЕРНЫХ КАДРОВ ДЛЯ ЭКОНОМИКИ 4.0

Актуальные аспекты взаимодействия российских и китайских образовательных организаций в интересах отраслевой экономики

*М.А. Гаранин, Цзэн Цинцзюнь*

## ЭКОНОМИКА МЕЖДУНАРОДНЫХ ПЕРЕВОЗОК И ЛОГИСТИКИ: ИНТЕЛЛЕКТУАЛЬНЫЕ И ЦИФРОВЫЕ РЕШЕНИЯ И ПРАКТИКА

Судостроительная отрасль России: состояние и проблемы стратегического развития

*Н.Е. Терешкина, О.А. Халтурина*

## ИСТОРИЯ ТРАНСПОРТА

Высокоскоростная железная дорога. Эффект работы предыдущих успешных проектировщиков

*И.П. Киселев*

Review article

UDC 656.2

doi: 10.46684/2025.3.01

EDN NSOROR

## From the first public railway to high-speed rail transport. The 200th anniversary of the Stockton and Darlington Railway, England, and the 12th World Congress on High-Speed Rail 2025 in Beijing

Igor P. Kiselev

Emperor Alexander I St. Petersburg State Transport University (PGUPS); Saint Petersburg, Russian Federation; kiselev@pgups.ru

**ABSTRACT** On September 27, 1825, the world's first public railway, Stockton and Darlington, was opened in England, marking the beginning of railway transport, the current technical and technological achievements of which are largely embodied by high-speed railways. In July 2025, the 12th World Congress on High-Speed Rail in Beijing noted the continuity of the history of railway transport, from the first railways to high-speed railway lines, and discussed the prospects for their development. The first congress on high-speed rail was held in Brussels in 1992. Since then, the congresses, which are held by the International Union of Railways (UIC) every 2–3 years, have become a traditional forum for representatives of government and public organizations from different countries, railway companies, scientific and design institutes, manufacturers of rolling stock and other railway equipment, as well as universities engaged in the training of professionals for the transport industry. The purpose of the meetings is to review the implemented projects and make proposals for the development of high-speed services – a particularly important segment of railway transport. Igor Kiselev, a railway engineer, Doctor of Historical Sciences, Professor Emeritus of Emperor Alexander I St. Petersburg State Transport University (PGUPS), and Chief Scientific Editor of the BRICS Transport Journal, talks about the history of railways and the congress held in Beijing. In the light of the implementation of the first St. Petersburg–Moscow high-speed railway project in Russia, the results of the congress are of great interest to those engaged in railway transport, as well as employees of research organizations and specialized higher educational institutions.

**KEYWORDS:** first public railway; Stockton; Darlington; England; Beijing; China; Congress on High-Speed Rail; HSR; International Union of Railways

**For citation:** Kiselev I.P. From the first public railway to high-speed rail transport. The 200th anniversary of the Stockton and Darlington Railway, England, and the 12th World Congress on High-Speed Rail 2025 in Beijing. *BRICS Transport*. 2025;4(3):01. <https://doi.org/10.46684/2025.3.01>. EDN NSOROR.

Обзорная статья

## От первой железной дороги общего пользования к высокоскоростному железнодорожному транспорту. 200 лет железной дороги «Стоктон и Дарлингтон», Англия и 12-й Всемирный конгресс по высокоскоростным железным дорогам 2025 г. в Пекине

И.П. Киселев

Петербургский государственный университет путей сообщения Императора Александра I (ПГУПС); г. Санкт-Петербург, Российская Федерация; kiselev@pgups.ru

© Igor P. Kiselev, 2025

© Translation into English "BRICS Transport", 2025

**АННОТАЦИЯ** 27 сентября 1825 г. в Англии была открыта первая в мире железная дорога общего пользования «Стоктон и Дарлингтон», положившая начало железнодорожному транспорту, технические и технологические достижения которого сегодня во многом олицетворяют высокоскоростные железнодорожные магистрали. В июле 2025 г. на состоявшемся в Пекине XII Всемирном конгрессе по высокоскоростным железным дорогам в выступлениях участников отмечалась преемственность истории железнодорожного транспорта от первых железных дорог до высокоскоростных, обсуждались перспективы их развития. Первый конгресс по высокоскоростному железнодорожному транспорту прошел в Брюсселе в 1992 г. Подобные конгрессы собираются раз в 2–3 года Международным союзом железных дорог. Они стали традиционным форумом представителей государственных и общественных организаций разных стран, железнодорожных компаний, научных и проектных институтов, предприятий выпускающих подвижной состав и другую железнодорожную технику, а также университетов, занятых подготовкой специалистов транспортной отрасли. Цель встреч – анализ осуществленных проектов и выработка предложений по развитию столь важного сегмента железнодорожного транспорта, как высокоскоростные сообщения. Об истории железных дорог, о состоявшемся в Пекине конгрессе рассказывает его участник, а также участник десяти предыдущих конгрессов инженер путей сообщения, доктор исторических наук, почетный редактор журнала «Транспорт БРИКС» Игорь Киселев. В свете реализации в России проекта первой высокоскоростной магистрали Санкт-Петербург – Москва итоги конгресса представляет большой интерес для работников железнодорожного транспорта, научных и профильных высших учебных заведений.

**КЛЮЧЕВЫЕ СЛОВА:** железная дорога общего пользования; Стоктон; Дарлингтон; Англия; Пекин; КНР; конгресс по высокоскоростным железным дорогам; ВСМ; Международный союз железных дорог

**Для цитирования:** Киселёв И.П. От первой железной дороги общего пользования к высокоскоростному железнодорожному транспорту. 200 лет железной дороги «Стоктон и Дарлингтон», Англия и 12-й Всемирный конгресс по высокоскоростным железным дорогам 2025 г. в Пекине // Транспорт БРИКС. 2025. Т. 4. Вып. 3. Ст. 1. <https://doi.org/10.46684/2025.3.1>. EDN NSOROR.

## FROM FIRST STEAM LOCOMOTIVES TO HIGH-SPEED TRAINS. MILESTONES OF INCREASING RAIL TRAVEL SPEEDS

On September 27, 1825, the world's first public railway, Stockton and Darlington, was opened in England, marking the beginning of railway transport. From the 16th century, trackways were in use in some European countries solely as industrial transport for transporting goods for small distances at mines, quarries, and factories (Fig. 1).

In Russia, the first trackway with cast-iron L-shaped angle rails ("wheel tracks") domestically made was built at the Aleksandrovsky Factory in Petrozavodsk in 1788. Elements of this line's rail track have survived to this date (Fig. 2).

The construction of the first 40-km long intercity public railway, the Stockton & Darlington Railway, was organized by outstanding engineer George Stephenson (1781–1848) and businessman, promoter, and head of the construction Edward Pease (1767–1858). They overcame incredible organizational difficulties, built up public opinion in favour of building railways, brought together influential politicians and businessmen, raised funds, and successfully implemented the railway project using the state-of-the-art engineering and technological solutions. The best track of the time made of cast-iron and iron rails was laid and steam engines — the engineering marvel of the 19th century

— began to be regularly used for the first time to haul trains. The Stockton & Darlington Railway was the world's first public commercial railway company that offered cargo and passenger transportation services for a predetermined fee to everyone (Fig. 3).



**Fig. 1.** Drawing of a mine road with a trolley, considered to be the first published drawing. 16th century. Fragment of an engraving. Universal Cosmography (Latin: Cosmographia universalis, 1544), a book by Sebastian Münster (1488–1552) [1]

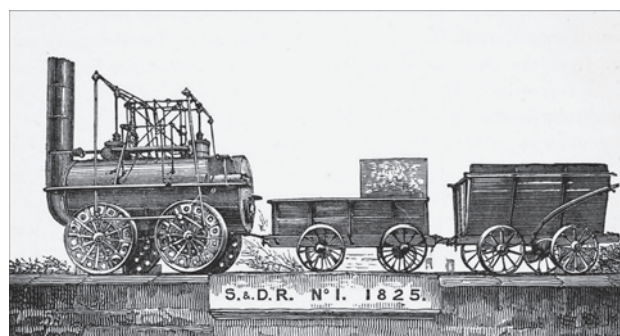

**Fig. 2.** Surviving iron-cast wheel tracks of the trackway at the Aleksandrovsky Factory in Petrozavodsk. Permanent exhibition of the National Museum of the Republic of Karelia. 2017.  
Photo by Mikhail Semenov<sup>1</sup>



**Fig. 3.** John Dobbin (1815–1888). The opening of the first public railway Stockton & Darlington on September 27, 1825. Wash drawing, from a sketch by John Dobbin made at the age of 10 after attending the opening event. 78 × 133 cm, 1871. Science Museum. London<sup>2</sup>.

The picture shows the first train hauled by locomotive *Active* (later renamed *Locomotion No. 1*). The train consisted of *Locomotion* (a locomotive with a tender), eleven wagons of coal, the carriage “*Experiment*” (it can be clearly seen in the picture: the eighth wagon, including the tender, from the locomotive), and further 20 wagons of passengers: special guests, and construction workmen



**Fig. 4.** *Locomotion No. 1*<sup>3</sup>, the first steam locomotive of the Stockton and Darlington Railway, with a tender and one coal wagon kept as a monument<sup>4</sup>

The creation of the Stockton and Darlington Railway changed the paradigm of railways. From a *special-purpose* industrial transport suitable for carrying goods over short distances they turned into *all-purpose* intercity — and later international — railway transport for a wide range of customers: passengers, freight carriers, and consignors. The Stockton and Darlington Railway set a model of success both in terms of transport and commerce: *until 1860, the company was the most profitable railway in Great Britain with the average annual profit margin of 9.5%* [2].

Chief engineer George Stephenson built two important railways: the Stockton and Darlington Railway in 1825 and the Liverpool and Manchester Railway in 1830. Many historians consider the two to be one large project. Thanks to these railways, railway transport began to develop throughout the world.

The first steam locomotives travelled at a walking speed of about five km/h, but even so, they aroused fear in common people. It is notable that a horseman with a red flag was to ride in front of the train hauled by a locomotive to warn of danger on the Stockton and Darlington Railway. However, on the very first day of the railway opening, September 27, 1825, the train with *Locomotion No. 1* (Fig. 4) several times already reached a speed of about 15 km/h, forcing the riding “signalman” to give way, so that he later had a hard time catching up with the locomotive...

In 1829, the owners of the intercity railway Liverpool & Manchester, which was then under construction, tested locomotives for speed in order to find the

<sup>1</sup> [https://commons.wikimedia.org/wiki/File:National\\_museum\\_of\\_Karelia\\_\(1\).jpg](https://commons.wikimedia.org/wiki/File:National_museum_of_Karelia_(1).jpg)

<sup>2</sup> <https://collection.sciencemuseumgroup.org.uk/objects/co227670/opening-of-the-stockton-darlington-railway-ad-1825-from-a-sketch-by-the-artist-at-the-time>

<sup>3</sup> The locomotive was purchased, repaired (restored) and preserved by descendants of Edward Pease 50 years after the railway was built. Nowadays, the locomotive is exhibited at various exhibitions and in museums according to special regulations.

<sup>4</sup> Commemorating the past, shaping the future: the jubilee and centenary celebrations of the Stockton and Darlington Railway. URL: <https://journal.sciencemuseum.ac.uk/article/commemorating-the-past-shaping-the-future-the-jubilee-and-centenary-celebrations-of-the-stockton-and-darlington-railway/>

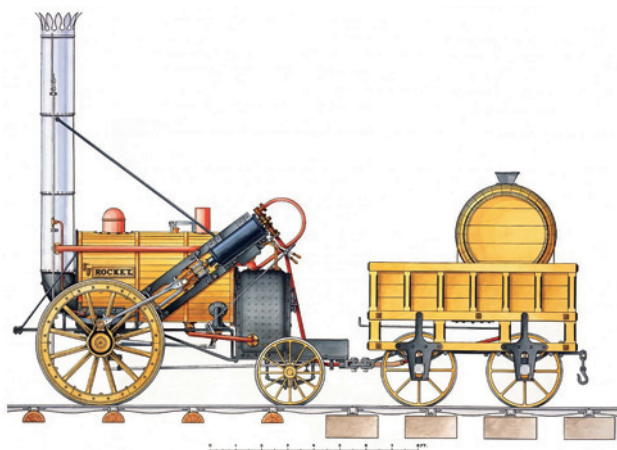

**Fig. 5.** Stephenson's Rocket – a steam locomotive with a tender as it was presented for a competition in 1829. National Railway Museum, UK / CCA 4.0<sup>5</sup>

best traction system. The famous competition (races) of steam locomotives was held in the area of Rainhill Station. The Rocket steam locomotive (Fig. 5) built by George Stephenson and his son Robert showed the average travel speed of 12 km/h during tests and achieved a maximum speed of 30 km/h. The creators were declared the winners [3].

This event — the world's first high-speed tests of steam engines — is the benchmark for the milestones of speed records in rail transport. For a long time, many historians believed the “round” number of 100 mph (160.9 km/h) to be a kind of boundary between normal traffic and high-speed traffic<sup>6</sup>. This speed limit was broken by *Hurricane*, a single speed steam locomotive, in a test (record-breaking) run on the Great Western Railway in the United Kingdom in September 1839 [4] (Fig. 6).

By the end of the 19th century, the best regular passenger trains in technically developed countries reached speeds of 80–90 km/h.

Started by the legendary *Rocket*, the steam traction era continued into the mid-20th century. In the first decades of the 20th century, remaining unchallenged on railways, steam locomotives enabled the best express trains in commercial service to reach speeds of about 110–120 km/h.

The speed record of 126 mph (203 km/h) for steam traction that has not been broken to this day was set in 1938<sup>7</sup>. On July 3, 1938, **LNER Class A4 4468 Mallard** steam locomotive of the London and North Eastern Railway hauling a train of seven four-axle Pullman coaches (including a dynamometric carriage) reached a speed of 126 mph (203 km/h) (Fig. 7).

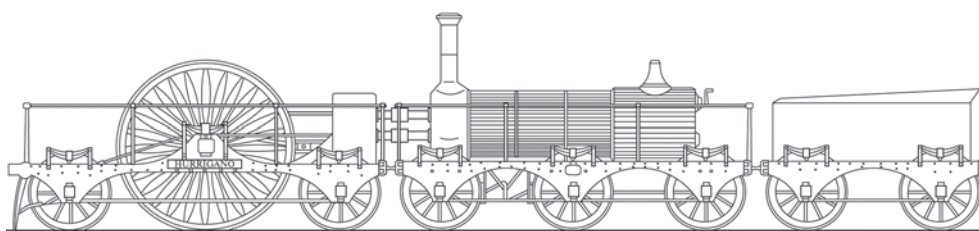

**Fig. 6.** Hurricane speed steam locomotive. Great Britain. 1839

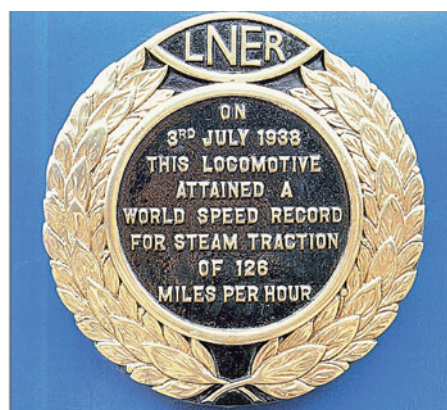
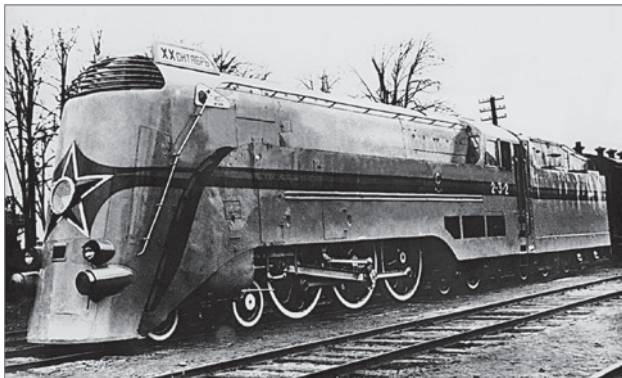

**Fig. 7.** Left: The fastest steam train in the world. Class A4 4468 Mallard steam locomotive, Great Britain. Photo taken in 1986. Right: Speed record commemorative plaque on the said locomotive. “LNER” at the top stands for the London and North Eastern Railway (the name of the railway) [5]

<sup>5</sup> The Rail Revolution. 2023. URL: <https://technichistory.com/2022/11/28/the-rail-revolution/>

<sup>6</sup> Let us note that 160 km/h is still considered the boundary between “ordinary” and “high-speed” traffic.

<sup>7</sup> This broke the speed record of 124.5 mph (200.4 km/h) set by the DRG Class 05 No. 002 steam engine in Germany in 1936.



**Fig. 8.** The first of the two fast 2-3-2-type steam locomotives built by the Kolomna Plant. USSR. 1937 [5]

In the 1930s, the USSR also created several fast steam locomotives with aerodynamic fairings. In 1937, a high-speed 2-3-2-type locomotive (Fig. 8) was built under the guidance of engineers Lev Lebedyansky and Mikhail Shchukin at the Kolomna Machine-Building Plant. On June 29, 1938, the locomotive hauling a 14-axle train on the Leningrad–Moscow line reached a speed of 170 km/h, setting the absolute speed record for steam trains in the USSR.

Before World War II, railways faced increased competition from aviation and road transport in high-speed passenger transportation over distances of 300–600 km. The railway industry responded with high-speed diesel trains which were widespread, in particular, in Germany and the United States. In 1933, SVT 877 high-speed diesel trains capable of reaching speeds of up to 165 km/h were put into regular operation on the Berlin–Hamburg line in Germany [5].

In the United States, one of the first successful attempts to use an internal combustion engine for speed traffic was a diesel train under the brand name “Pioneer Zephyr”<sup>8</sup> which consisted of three articulated carriages on intermediate bogies. On May 26, 1934, the Pioneer Zephyr<sup>9</sup> (Fig. 9) travelled non-stop from Chicago to Denver (1,633 km) in 13 hours<sup>10</sup> at an average speed of 125.5 km/h, with a maximum recorded speed of 181.0 km/h [7].

Some countries, such as Sweden, Switzerland, Italy, Germany, and the USSR, increased the rates of railway electrification, expanded suburban transportation by electric trains around large cities, and created the first high-speed electric trains. On July 20, 1939, the ETR 200 electric multiple unit travelled along the Florence–Milan (314 km) line in Italy in 1 hour 55 minutes (average

speed: 164 km/h) with a maximum speed of 202.8 km/h [6a] (Fig. 10).

After World War II, the rates of replacing steam locomotives with diesel ones increased in both freight and passenger traffic first in the United States and later in other countries. By the 1950s, U.S. railway companies had stopped electrification of railways and focused instead on diesel locomotive operations, which required less investment.

At the same time, along with the introduction of diesel locomotive traction, the electrification of railways continued in the USSR (which ranked second after the United States in terms of railway network length), the majority of European countries, and later in Japan, China, India and a number of other countries.

By the early 1970s, steam traction had almost totally disappeared from trunk railway lines in most of the leading industrial countries.



**Fig. 9.** American diesel trains of the 1930s. Zephyr [7]



**Fig. 10.** ETR200 electric multiple unit. Italy. 1939 [7]

<sup>8</sup> The diesel train was named after American pioneers, or American settlers, of the 18th–19th centuries who travelled to western lands of the United States of America against the west wind. Zephyr (ancient Greek: Ζέφυρος) means “west wind”.

<sup>9</sup> The diesel train was named after American pioneers, or American settlers, of the 18th–19th centuries who travelled to western lands of the United States of America against the west wind. Zephyr (ancient Greek: Ζέφυρος) means “west wind”.

<sup>10</sup> According to a schedule, an express train with a steam locomotive travelled this route in 27 hours.



**Fig. 11.** Le Capitole express train between Paris and Toulouse – Europe's first train with a maximum speed of 200 km/h. Early 1960s [7]

Significant progress in high-speed railway traffic was achieved by France, where a train exceeded the 300 km/h mark in test runs in 1955. The CC 7107 and BB 9004 DC electric locomotives, each hauling a train of three carriages with a total weight of 111 tonnes, achieved speeds of 325 km/h and 331 km/h, respectively. In the early 1960s, on a number of railway lines in France, regular trains reached speeds of up to 200 km/h (Fig. 11).

In the post-war period, the USSR implemented an unprecedented General Plan for retrofitting the railway industry on the basis of electrification. In the 1960s, the progress in high-speed traffic achieved on the October Railway was comparable to the performance of high-speed express trains on railways of Japan, France, Italy, the United States, and other countries leading the way in this field. At that time, the Moscow–Leningrad line was on par with the best foreign rail lines in terms of travel speeds of passenger trains — and this was over a 650 km long route, which was two or three times longer than most of the railway lines abroad. In March 1966, a train with a ChS2M electric locomotive running on a block section on the Leningrad–Moscow line achieved a speed of 200 km/h for the first time in the history of Russia [8].

The process of railway speed increase before the emergence of dedicated high-speed lines is divided into three periods. The periodization is based on the two interrelating parameters: the record train speed and the maximum speed in commercial service. Period 1 — from the beginning to the middle of the 19th century — involved building the first high-speed (also known as “racing”) steam engines<sup>11</sup>. Period 2 — from the mid-19th century to the first decades of the 20th century — saw consistent increases in speeds of the best trains to 120–150 km/h, the beginning of competition of railways with air and road transport, and the end of the steam traction era after reaching its peak at the speed of 200 km/h. Period 3 — between the 1930s and the mid-1960s<sup>12</sup> — marked the switch to internal combustion engines and electric traction in high-speed traffic and the achievement of speeds of up to 200 km/h in commercial service. The current Period 4 (which started in the mid-1960s) involves the creation and development of dedicated high-speed rail lines [6a].

## HIGH-SPEED RAIL

In 1964, a historic event that opened a new page in the development of railway transport took place in Japan when the world's first dedicated high-speed rail service for passengers was launched between Tokyo and Osaka. It was 515 km long and was designed for regular traffic of trains with a maximum speed of over 210 km/h (Fig. 12). In terms of importance and consequences, this is comparable to opening of the first intercity public railway, the Stockton and Darlington Railway, in England in 1825. The concept of “dedicated high-speed rail” was established. First, the world widely used the term “Shinkansen”<sup>13</sup>. The acronyms “VSM” (for “high-speed main line”) or “VSZhM” (for “high-speed railway line”) have become entrenched in the Russian language.



**Fig. 12.** *a* – 0 (Zero-kei) series train – the world's first bullet train. Japan, 1964. Igor P. Kiselev's collection; *b* – Commercially available modern, newest E7 high-speed train, Japan. Tokyo Station. 2015. Photo by Igor P. Kiselev

<sup>11</sup> Some studies mention “the first intoxication of mankind with speed”. Record-breaking rides achieved speeds of over 100 mph, after which interest in speed steam locomotives faded.

<sup>12</sup> This includes the period of World War II and first post-war decade which saw a large decrease in travel speeds.

<sup>13</sup> In Japanese, “shinkansen” means “new trunk line” or “new main line”.

With the opening of the first HSR, the original paradigm of the high-speed railway transport has notably changed. Unlike most railways, HSR in its modern format includes purely dedicated passenger routes for large-scale services within strictly defined transport corridors. Before that, train traffic of various purposes and at various speeds — fast express passenger trains, ordinary long-distance passenger trains, suburban and freight trains — predominantly used the same (all-purpose) railway tracks. On rare occasions, usually in the vicinity of very large metropolitan cities, dedicated tracks were provided for suburban traffic. Dedicated freight rail lines were also created for large flows of homogeneous goods, such as coal, ore, other minerals, timber, etc.

High-speed rail laid the foundation for large-scale passenger transportation, initially at speeds of over 200 km/h and currently of up to 350 km/h with high levels of comfort and safety on shuttle routes between stations with high passenger flow generation. HSR using trains with seating coaches occupy a transport niche for distances of up to 600–800 km with an optimal travel time of about 2–2.5 hours.

“High-speed rail” is a historically developed, conventional concept. It is based on conventions and regulations, as there is no real-world boundary defining the speeds for “high-speed” rail traffic, as opposed to, for instance, the concept of “sound barrier” in aviation. In the first decades of the 20th century, “high-speed” rail traffic referred to the movement at a speed of 140–160 km/h, and by the end of the century, it meant travelling at a speed of up to 200–250 km/h [7].

According to the UIC materials distributed at the 12th World Congress on High-Speed Rail in Beijing on July 8–11, 2025 [9], high-speed rail (HSR) lines are “integral, integrated systems” with infrastructures for speeds of 250 km/h and above, modernized lines for speeds of up to 200 km/h, specially designed rolling stock, telecommunications and signalling systems without floor signals where train control data is communicated directly to the driver’s cabin, and certain operating conditions are met [10]. These lines are usually used on shuttle routes.

In Russia, Federal Law No. 4483-FZ dated November 30, 2024 “On Amending Federal Law “On Railway Transport in the Russian Federation”” describes high-speed rail transport as commercial transportation at speeds of over 200 km/h. The same law defines high-speed railway rolling stock as “railway rolling stock designed for carrying passengers and/or luggage, and mail at speeds of over 200 km/h” [11].

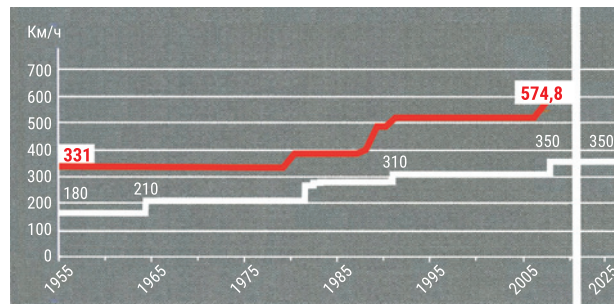

**Fig. 13.** Growth of record speed (red line) and speed of trains in commercial service (white line) on HSR lines worldwide (1955–2015). Diagram prepared by Igor P. Kiselev; source: [8, p. 10]

Between 1955, when the first Tokyo–Osaka HSR was built in Japan, and present, the registered record train speed on classic railways (wheel-rail system) has increased from 331 km/h<sup>14</sup> to 574.8 km/h (the V150 experimental train, France, April 3, 2007).

By now, the maximum speed of trains in regular service has increased from 210 km/h (Tokyo–Osaka, 1964) to 350 km/h on several HSR lines. No high-speed line in the world operates commercially at higher speeds<sup>15</sup> (Fig. 13).

Figuratively speaking, there is no market product called “high-speed railway and its rolling stock for commercial service at a speed of 400 km/h” in the world today.

At present, more than 64,400 km of specially built high-speed rail lines are in operation [8, p. 29], more than 20,000 km are under construction, about 20,000 km are being designed, and in the long run it is planned to build about 34,000 km more. The longest HSR lines are available in the following countries: China — 48,000 km [12]; Spain — 3,990 km; Japan — 3,140 km; France — 2,730 km; Germany — 1,630 km; Turkey — 1,230 km; Italy — 980 km; Republic of Korea — 870 km; Saudi Arabia — 440 km; Belgium — 200 km; Morocco — 180 km; Switzerland — 170 km; the United Kingdom — 110 km; the Netherlands — 90 km; Denmark — 56 km [13].

## 12TH WORLD CONGRESS ON HIGH-SPEED RAIL: REVIEW OF THE FIRST QUARTER OF THE 21ST CENTURY, AND PROSPECTS

The 2025 Congress was held in the giant China National Convention Centre in Beijing. It brought together about 2,000 participants: representatives of more than

<sup>14</sup> In France, an experimental train with an electric locomotive BB 9004 reached a speed of 331 km/h on March 29, 1955.

<sup>15</sup> According to media sources, trains with a design speed of 360 km/h are planned to operate on several sections of the existing high-speed railways in Italy and France. The High Speed 2 (HS2) London–Midlands line in the UK, which has been under construction since 2019, is designed for a maximum speed of 360 km/h.



Fig. 14. Congress meeting hall. Photo credit: UIC



Fig. 15. Roundtable session "Innovation for a Better Life".  
Photo by O. Nazarov

40 countries and employees of the Chinese railways, railway industry companies, scientists, employees of research and design organizations, professors and students of higher educational institutions in the field of railways (Fig. 14).

In his welcoming address to the congress participants, Vice Premier of the State Council of the PRC Zhang Guoqing noted that China was ready to share their achievements in the field of high-speed railways with other countries. According to him, by 2024, the length of high-speed railways in China reached 48,000 km, which is more than 70% of the total length of HSR worldwide.

At the opening ceremony, welcoming remarks were also made by President of the International Union of Railways Alan Beroud, President of China Railways Corporation Song Xiude, high-ranking representatives from Kyrgyzstan, Laos, Uzbekistan, Mongolia, and other countries.

The Congress included plenary sessions with panel discussions (Fig. 15–17), roundtables, and 30 break-out sessions where about 180 presentations were made by speakers from 26 countries. The reports were selected by an expert research team of the Congress Organizing

Committee from among a few hundreds of proposals received from many countries from those willing to take part in scientific discussions at the Congress.

The largest number of presentations (62) was delivered by scientists from the People's Republic of China. We believe that the number of reports made at the Congress shows the interest of the research and transport communities of a certain country in HSR issues, which is related to success in the implementation of HSR projects. Representatives of China were first with 62 presentations; Italy was second with 26 presentations, followed by Spain and France with 11 presentations each; Germany delivered 9 presentations; Japan made 6 presentations; the United Kingdom, Morocco and Poland of-



Fig. 16. Break-out session "Developing HSR network and stations". From left to right: Session moderator: Liu Lihai, Deputy Chief Engineer, China Railway, Siyuan Survey and Design Group Co., Ltd, China; Saad El Marzouki, Head of Production Department, TGV Office National des Chemins de Fer (ONCF), Morocco; Aleksandar Dobrijevic, Deputy Director, Institute of Traffic and Transport Ljubljana, member of SEESARI Institute of Traffic and Transport Ljubljana and SEESARI (Initiative for supporting rail and transport development in South East Europe), Slovenia; Zhou Lingyun, Head of Department, China Academy of Railway Sciences (CARS), China; Igor Kiselev, Professor, Emperor Alexander I St. Petersburg State Transport University, Russian Federation; Graham Nelmes, General Manager, Customer, Place and Operations, High Speed Rail Authority, Australia. Photo by O. Nazarov



Fig. 17. In the meeting room of the break-out session "Developing HSR network and stations". Photo credit: UIC

ferred 3 presentations each; Australia, Switzerland and the Republic of Korea were represented by 2 speakers each; and the other countries represented in scientific discussions (Belgium, Bulgaria, Iran, Canada, Norway, Peru, Russia, Saudi Arabia, Slovenia, the United States, Finland, and Sweden) each had one speaker.

As was mentioned above, the Congress had six parallel break-out sessions, each broken into five sub-sessions. Thus, there were in total 30 sessions with the topics that, according to the Congress organizers, outlined a range of relevant scientific, engineering, financial, economic, social, environmental and other issues in the development of high-speed rail transport.

The themes of the Congress sessions were as follows:

1. Artificial Intelligence and Digital Innovation.
2. Infrastructure and Superstructure.
3. Socio-Economics, Environment and Commercial.
4. Rolling Stock and New System Performance.
5. System Operations and Passenger Experience.
6. Network Development and Stations.

The author is planning to use the materials (speaker papers and presentations) published by the Congress Organizing Committee to review the current academic and engineering areas of research in the field of high-speed rail that were considered by professionals from different countries and presented at the Congress for publication.

The Congress participants reviewed important areas of academic, engineering, design and organizational activities for the design, construction and operation of high-speed rail lines. In particular, they touched upon the issues of using artificial intelligence technology and digital innovation, improvement of the infrastructure, rolling stock development; socio-economic, environmental and commercial aspects of HSR; improvement of control systems and provision of safety, operation and passenger services; development of HSR networks, stations, and many more. Interestingly, the subject of magnetic levitation transport has currently lost its relevance, although some participants still mentioned it in their presentations. Besides, a driving trailer of a Chinese maglev train was demonstrated at the exhibition.

The 17th China International Modern Railway Technology and Equipment Expo which attracted 521 participants from 14 countries was held simultaneously with the Congress in the same giant complex of buildings of the Beijing National Congress Centre (Fig. 18). The exhibition area was about 49,000 sq. m (the size of more than five football pitches<sup>16</sup>) [14, 15].

The exhibition regularly held every two years is organized by the Chinese Academy of Railway Sciences

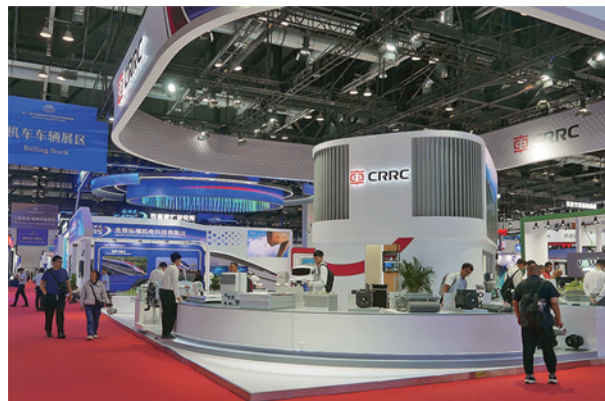

a

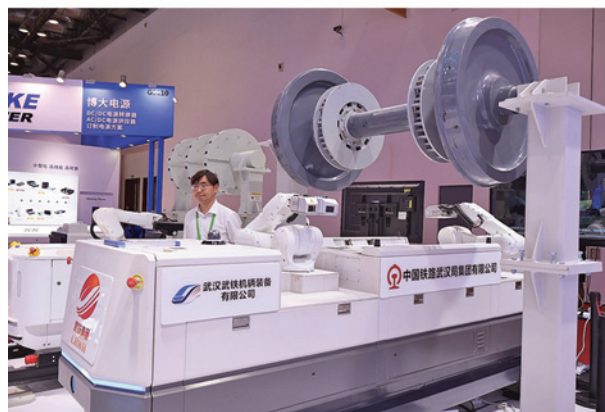

b

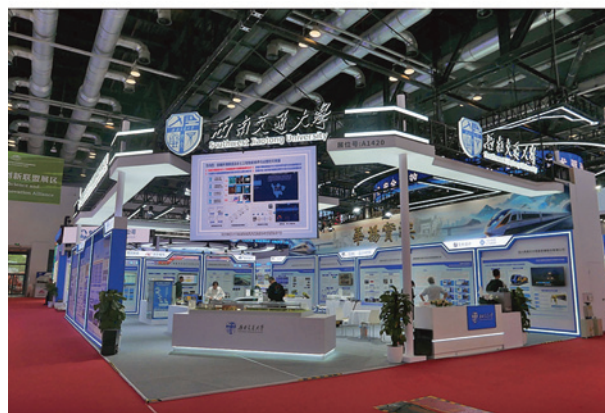

c

**Fig. 18.** The 17th China International Modern Railway Technology and Equipment Expo: *a* – Stand of China Railway Rolling Stock Corporation (CRRC). Photo by the author; *b* – Robotic installation for comprehensive testing of wheel sets at the Wuhan Locomotive Plant; *c* – Stand of the Southwest Railway University. Photo by the author

and the China World Trade Centre in coordination with the Ministry of Commerce of the PRC and China State Railways. The majority of participants are Chinese companies; however, many world leading rolling stock

<sup>16</sup> According to the accepted average parameters, the “ideal” football pitch for a game between two teams of 11 players each should be 105 m by 68 m, with the area being 7,140 sq. m.



**Fig. 19.** General view of the exhibition on the test ring tracks of the National Railway Testing Centre of the Chinese Railway Academy. Photo by the author



**Fig. 20.** China's new CQS-300 ballast cleaning machine intended for operations on turnouts with 4,800 mm reinforced concrete turnout sleepers. Photo by the author

and railway equipment manufacturers and design organizations present their products at the exhibition.

On one of the Congress days, the participants were introduced to activities of the National Railway Testing Centre of the Chinese Academy of Railway Sciences located in a close suburb of Beijing in the northeast, outside the 5th Ring Road.

The Centre's test ring was designed and built with the involvement of professionals from the USSR in 1958. In terms of its basic engineering solutions, it looks like the experimental railway ring of the Railway Research Institute (VNIIZhT JSC) in Shcherbinka<sup>17</sup>; however the Chinese test ring has a large diameter and, hence, longer tracks, which makes it a good place for tests, even at high speeds. On April 18, 2023, a speed record of 222.2 km/h for a train running on the experi-

mental ring was set there. This points to the vast opportunities for Chinese researchers and specialists in various experimental operations [16].

The Congress participants familiarized themselves with work of several laboratories of the Centre, in particular, for brakes, current pickup, wheel set testing, and others.

## LIGHTER AND FASTER

A few dozens of samples of railway equipment, including electric passenger trains intended for various purposes, locomotives, track machines, etc., were exhibited on the tracks of the Centre (Fig. 1–23). The strongest “attractors” were certainly the two latest

<sup>17</sup> <https://wagon-cargo.ru/news/generalnyy-direktor-sergey-vinogradov-i-eksperty-ao-vniizht-stali-uchastnikami-vystavki-modern-railw/>



**Fig. 21.** China's eight-carriage high-speed electric multiple unit for suburban and urban services with the design speed of 200 km/h. It can accommodate 1,592 passengers in seating. Photo by the author



**Fig. 22.** China's experimental CR450 AF high-speed electric multiple unit with the design speed of 450 km/h. You can clearly see the stamped three-dimensional silhouette of an arrow on the hull plating – an element of the train brand. Photo by the author



**Fig. 23.** China's experimental CR450 BF high-speed multiple unit with the design speed of 450 km/h. The designers' idea is that the nose fairing of the driving trailer should look like a falcon beak – an element of the train logo. Photo by the author

models of the CR450AF and CR450BF experimental trains “facing” each other on the first track.

Unfortunately, the Congress participants were allowed to see and take plenty of pictures of only the exterior of these beautiful trains. Exhibition participants are not allowed inside wagons, as the interior design has not been completed and some carriages have measuring and control equipment for tests on-board.

Since 2021, China has been implementing the CR450: Science and Technology Innovation Project (Chinese Railways 450 [km/h]), a national programme aimed to define key technologies for achieving train speeds of 400 km/h in commercial service [15]. As was noted above, today, there are no HSR lines and trains for them able to travel at a maximum speed of 400 km/h in regular traffic.

Attempts to create such trains and infrastructures were previously made in the Republic of Korea (South Korea) and Japan. In 2007–2013, the Republic of Korea carried out a project for the creation of the HEMU 430X<sup>18</sup>, a train with the design speed of 430 km/h (and a maximum service speed of 400 km/h), and also planned to build a HSR line with these parameters. The project did not succeed and was closed in 2013 [17, 18].

In 2005–2009, Japan implemented a project that involved building two experimental trains, Fastech 360S and Fastech 360Z, which passed tests successfully. As a result, they were used as a basis for creating an experimental train E956 ALFA-X<sup>19</sup> with the design speed of 400 km/h. The project has been underway since 2016. Tests conducted in 2019 showed good results and a prototype of the E10 train is currently being manufactured. Its testing and commercialization are planned to take place before 2030 [19, 20].

Thus, China is the third country that has embarked on harnessing the speed of 400 km/h in commercial service. In China, the CR450 project has created prototype trains and elements of the new infrastructure, which, as Chinese experts put it, should ensure entering the “uncharted territory”. What is meant is that a speed of up to 350 km/h has already been achieved in commercial service on classic high-speed rail (HSR) lines, and, as anticipated by scientists, the speed range of 450 km/h and higher is for magnetic suspension (maglev) transport.

The two prototype high-speed trains with the design speed of up to 450 km/h, CR450AF and CR450BF, presented at the exhibition were designed independently by two subsidiaries of CRRC<sup>20</sup>, CRRC Changchun Rail-

<sup>18</sup> HEMU 430X (High Speed Electric Multiple Unit-430 eXperimental) is an experimental multiple unit electric train designed to achieve a maximum speed of 430 km/h.

<sup>19</sup> Advanced Labs for Frontline Activity in rail eXperimentation.

<sup>20</sup> 中国中车股份有限公司 CRRC Corporation Limited (China Railway Rolling Stock Corporation) is a Chinese corporation, the world's major manufacturer of railway rolling stock accounting for about one half of the global market.

way Vehicles and CRRC Sifang, using the same specifications developed by China Railway (CR).

The company used its own solutions, relying solely on Chinese technologies, to create the train. To date, these have been implemented in high-class trains CR400AF Fuxing (put into operation in 2016; more than 300 trains (the eight-carriage model) were manufactured) and CR400BF Fuxing (put into operation in 2016). The goal of the CR450 programme is to utilize the achievements of Chinese scientists and specialists in science and engineering to improve the characteristics and reach, first of all, the speed limit of 400/450 km/h.

The new trains combine all the state-of-the-art solutions in design and construction of high-speed rolling stock that have been achieved by Chinese scientists and specialists. As a result, according to CRRC, with the design speed of 450 km/h and a planned commercial service speed of 400 km/h, the total weight of the CR450 train is reduced by 10% compared to the previous production model, in particular, due to the use of 10% of carbon fibre-based elements in the train body.

The axle load is about 14.5 tonnes. The tractive resistance is 22% lower than in the CR400; the adhesion capacity is improved by 4%; the braking capacity is increased by 20%; and the emergency braking distance is less than 6,500 m. Power consumption at a speed of 400 km/h has been reduced by 20% to 22 kWh/km, and the noise levels are 2–4 dB lower — less than 68 dB in the central part of the carriage [15, 21, 22].

The train uses permanent magnet synchronous motors<sup>21</sup> and traction converter systems with water-based cooling solutions. While the CR450 has a higher total tractive power — 11,000 kW (against 9,600 or 10,400 kW in CR400 trains), its propulsion system sets have become lighter and more efficient by 2–3%.

Highly stable new generation bogies have been designed for the trains. To create them, nine modern technologies were developed, including an eddy-current brake and carbon ceramic brake disc.

Safety is provided by a multi-level emergency braking control system and more than 4,000 built-in sensors for continuous monitoring of critical units and components. The automatic system monitors the condition of the train's undercarriage, body, pantographs, propulsion equipment, train control, and fire-fighting systems in real time.

The CR450AF has successfully passed tests at a speed of over 420 km/h, with a maximum speed of 453 km/h. The tests were carried out on a section with

a bridge across Meizhou Bay and a tunnel in Haiwei. The speed reached by the train while running on these artificial structures was 453 km/h and 420 km/h, respectively. Further tests are planned to be conducted, in particular, on a section of the Chengdu–Chongqing high-speed railway [23].

The section infrastructure is reconstructed, including the replacement with new elements that will enable movement at a speed of up to 400 km/h. These, in particular, include specially designed rail fastenings and turnouts, new so-called “flat welded rail bonds” — the barriers to reduce noise levels. Moreover, to provide traffic at new speed levels, the subgrade formation was improved to increase stability, and changes to the design of bridges and viaducts were made.

The prototypes of high-speed trains for the speed of 450 km/h were among the main attractions of the exhibition.

Like their predecessors, the new eight-carriage trains have four two-carriage sections, each consisting of a motor carriage and a trailer carriage. The end (control) trailers have a control cabin. The two-carriage section has a full set of necessary electric and pneumatic equipment. Pantographs are installed on the roof of the third and sixth carriages, and only one of them is used under the normal operation. The high-voltage cable that runs between carriages is installed in the ceiling void.

The layout, finishing and furnishing of passenger compartments of the new trains will rely on the high performance achieved when creating the previous series CR400AF Fuxing and CR400BF Fuxing that have been proven in operation by both experts and passengers.

Much effort in creating the new trains was focused on improving the aerodynamic properties of high-speed rolling stock, with air resistance being of primary importance. According to research data, at a speed of 300–350 km/h, up to 75% of the traction effort is spent to overcome the aerodynamic component of resistance to movement. At a speed of 400 km/h, resistance increases by another 30% and up to 95% of energy is spent to overcome air resistance [15, 22, 23].

According to media sources, a dedicated technical team of China Railway, which included employees of the Academy of Railway Sciences, the Faculty of Engineering Sciences at the University of the Chinese Academy of Sciences, the Institute of Mechanics of the Chinese Academy of Sciences, and several trans-

<sup>21</sup> Synchronous machines use permanent magnets to create and maintain the electromagnetic field of the rotor without consuming additional energy from the system. Permanent magnet synchronous motor (PMSM) is an electromagnetic motor with the inductor made of permanent magnets. Permanent magnet motors reduce energy loss in the system and do not require current to be applied to the exciting winding via the slip rings. These motors have 2–3% higher efficiency compared to high-performance asynchronous electric motors and dimensions that are 20–30% smaller with the same output.

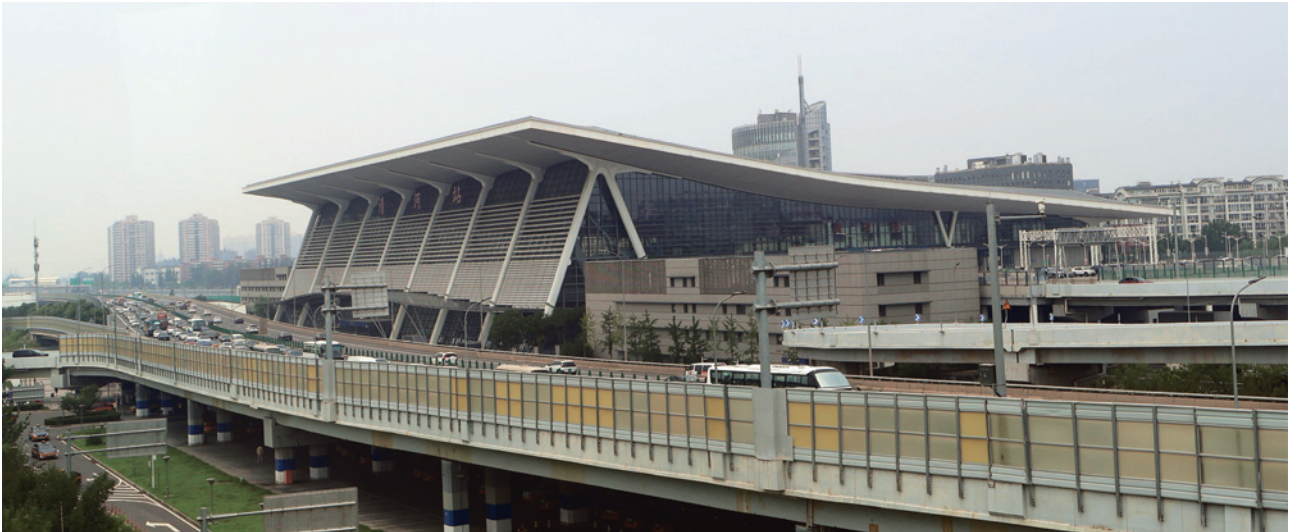

Fig. 24. Qinghe Station building, which is often referred as the West Railway Station of Beijing. Photo by the author

port universities, developed and proposed more than 100 shape design solutions for the nose of the driving trailers based on bionics. After hundreds of tests on mathematical models and wind tunnel experiments, two shape designs have been finally chosen for the nose: one shaped as a flying arrow for the CR450 AF (please see Fig. 22) and the other resembling a falcon beak for the CR450 BF. While the “flying arrow” is clearly distinguishable on the side view of the trailer, the “falcon beak” requires, in the author’s opinion, a good deal of imagination to discern (please see Fig. 23).

According to executives of China Railway, a large set of tests are to be conducted before 2028 on both train prototypes and all the relevant infrastructure elements.

Back to the Congress, let us note that in the 40-degree heat that hit Beijing at the time, examining a variety of modern rail vehicles exhibited on the tracks of the Centre was quite a challenge for the participants, most of whom had photography equipment with them. In contrast, visiting the laboratory buildings to see very interesting equipment was much more relaxing as they are equipped with powerful air-conditioning systems which pumped icy-cold air into the rooms. But having gone through hardships, the Congress participants were rewarded with extremely interesting information about the current progress in railway science and technology in China.

## FIRST-HAND EXPERIENCE

On the final day of the Congress, the participants had a technical visit to the facilities of two HSR stations (Fig. 24) and a ride on a CR400 BF high-speed train — one of the latest modifications of the rolling stock (design speed: 400 km/h; service speed: 350 km/h).

The CR400 AF and CR400 BF are currently the most used, most comfortable and the fastest trains on China’s HSR network. The trains represent a concentration of Chinese brands: the resulting product developed by Chinese scientists and engineers, which formed the basis for the creation of the next generation of trains branded “Fuxing” (meaning “rejuvenation” in Chinese).

The CR400BF-GS 5337 (Fig. 25) provided to carry the Congress participants is an eight-carriage electric multiple unit (with four motor carriages and four trailer carriages with a total power of 10,400 kW) that can accommodate a maximum of 619 passengers. Based on the fleet number 5337 (according to the reference tables found online), the train was one of the ten EMUs manufactured by CRRC Changchun Railway Vehicles Co., Ltd in December 2024 and put into operation in January 2025. In total, 38 trains of this modi-



Fig. 25. The driving trailer of the CR400BF-GS 5337, which Congress participants travelled on. Photo by the author



a



b



c

**Fig. 26.** CR400BF high-speed train: *a* – Business Class coach interior with individual mechanized seats that are referred to as “eggshell” in China for the similar appearance of the cover. Passengers can set the seat in the “bed” position on their own using a remote control. Photo by the author; *b* and *c* – First Class coach interior. Passengers can turn the seats on their own to sit facing the engine. Photo by the author

fication were manufactured. This version of the train was structurally designed as more resistant to sand storms and cold climate for use in extreme weather conditions. Its design includes a number of the latest solutions that distinguish it favourably from the base model put into operation in 2016. We are referring to a new modular traction transformer and new electrical distribution cabinets. By improving the layout of the interior of coaches, the train’s passenger carrying capacity was increased by 42 persons (38 second-class seats and 4 first-class seats). The CR400BF-GS train modification was further tested in 2024 [24].

The Congress participants examined the interior design of the coaches which are divided into three classes: Business (the top level of seating comfort in China): individual extra comfort seats with three seats in a row; First Class: four seats in a row (2+2); and Second (Economy) Class: five seats in a row (2+3).

Let us note that the designer of Russia’s new high-speed train for the Moscow–St. Petersburg HSR is planning to use approximately the same classification of coaches. Let us recall, that second-class coaches of the *Sapsan* have four seats in a row, while the carriage width is the same as in China’s trains intended for HSR. Seating arrangement with five seats in a row will, certainly, be rather cramped for Russians who are generally bigger. Perhaps, this will be compensated for by a lower fare.

On Chinese trains, passengers can visit a buffet carriage (Fig. 27), while business and first-class passengers

are served food and drinks at their seats. The train has dedicated seats for passengers with reduced mobility provided with anchorage for securing wheelchairs.

The train has two types of sanitary facilities: the “European” type, which is customary to us, and so-called “Eastern toilets” when a flat toilet is built into the floor. There is also a dedicated toilet for people with disabilities.

During the trip, Russian participants conducted an experiment to verify that the train was moving very smoothly thanks to its design and the perfect condition of the track. China’s media like to describe the experiment in their reports about HSR. We repeated the test



**Fig. 27.** Buffet counter. Photo by the author

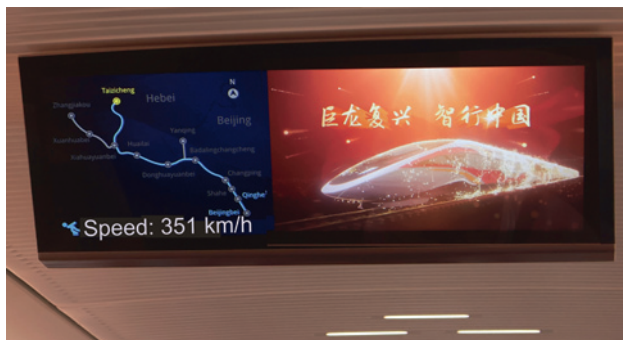

**Fig. 28.** Information board in the passenger compartment of the CR400BF train showing the current speed of 351 km/h



**Fig. 29.** The coin standing still on its edge at a speed of 350 km/h

several times and testify to its success. When the train ran at a speed of about 350 km/h (as was seen on the information board (Fig. 28)), we put a coin on its edge on the window sill (Fig. 29). The coin stood still as long as the train travelled in a straight line. When it began to brake, the coin naturally started to roll.

It took the train 55 minutes to travel about 190 km from Qinghe Station, which is often referred to as the Western Railway Station of Beijing, to Taizicheng Station, developing a speed of up to 350 km/h on several sections.

Two kilometres from Taizicheng Station (Fig. 30), there is the Olympic Village of the 2022 Winter Olympics, which is located at an altitude of 1,582 m above the sea level (Fig. 31). Very close to the neighbouring Badaling Station, you find the cyclopean structures of the Great Wall. All this makes the route of the Beijing–Chongli high-speed railway quite popular with tourists.

### WHAT'S THE BOTTOM LINE?

In general, the 12th World Congress on High-Speed Rail was a special event for China's railways.

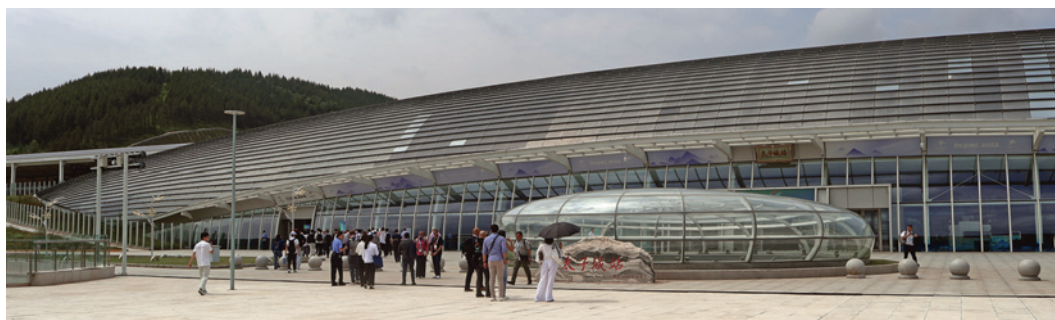

**Fig. 30.** Taizicheng Station building at an altitude of 1,582 m above the sea level close to the Olympic Village of the 2022 Winter Olympics. Photo by the author



**Fig. 31.** Olympic Village of the 2022 Winter Olympics

China presented its ambitious programme for expanding the HSR network and increasing train speeds. By the end of 2025, the length of China's HSR network will exceed 50,000 km, and by the end of 2035, China Railway plans to expand the HSR network to 70,000 km and increase the maximum commercial operating speed to 400 km/h, President of China Railway (CR) Xiude Song reported. This will make the Chinese network the fastest in the world. It is planned to create eight so-called "vertical" and eight "horizontal" lines (Fig. 32). By now, about 80% of the planned network has been completed; and the work is ongoing [25, 26].

In China, high-speed trains serve about 97% of cities with a population of above 500,000 people. More than

10,000 high-speed trains currently run in China, carrying 16 million passengers per year, Xiude Song said.

China is planning to expand, both literally and figuratively, the boundaries of its high-speed transport. The projects that are implemented under the leadership of China in Laos, Indonesia, Hungary, and Serbia were presented during the Congress. Senior officials from Kyrgyzstan, Mongolia, and Uzbekistan, where China also plans to contribute to the construction of high-speed railways, gave addresses at the opening ceremony.

According to Vice-Premier of the State Council of China Zhang Guoqing, in the early days of high-speed network development in the 2000s, the industry was



**Fig. 32.** Prospective plan of high-speed rail lines in PRC "Eight vertical and eight horizontal" lines as part of the Middle- and Long-Term Railway Development Plan in PRC (2016–2025 Development Period) published by the National Development and Reform Commission of the PRC, the Ministry of Transport of the PRC, and China State Railway on July 16, 2016 [25, 26]. Plan adapted by Igor P. Kiselev. Source: [27] In the diagram, the names of the "horizontal" lines are outlined in gray, and the names of the "vertical" lines are outlined in green

dependent on foreign suppliers, but China has fully mastered key technologies in the construction, manufacturing of equipment for, and operation of high-speed railways. “We have quickly made up ground and we are keeping abreast of the schedule, and now we are even ready to become world leaders”, he said.

To sum up the outcomes of the Congress, let us note the following. The most important thing is that high-speed rail transport has utterly moved from experiments to regular daily use available to the general public in many countries. HSR lines confidently occupy a transport niche within a range of distances of up to 800–1000 km with maximum speeds of up to 350 km/h and travel times of 2.5–4 hours.

In addition to the above, Chinese railwaymen have tapped another transport niche: passenger services at speeds of 250–350 km/h over a distance of about 1,000 km on high-speed trains with sleeper coaches with four-berth compartments.

There are more and more regions that set out to build and expand high-speed rail. The emerging economies and middle-income countries are active with updating their maps of future high-speed railways, which shows that the transition from demonstration to implementation is in full swing. Investments in high-speed railways are no longer limited to those countries that have developed them earlier but are gaining global momentum with lots of points of entry and a growing exchange of knowledge, standards, and best practices.

The Congress has also shown that innovations in the field of high-speed rail are no longer limited to trains and tracks, but also encompass systems and services. An integrated ticketing system, AI-powered automated services, low-carbon construction technology, intermodal connectivity, and passenger-centric design

of stations — all this shapes the next generation of railway transport.

The high-speed rail sector is moving from the narrow focus on speed to a broader approach focused on intelligent, efficient and user-friendly transport systems, turning high-speed rail into a platform for seamless and inclusive mobility. Many sessions at the Congress were focused on how to implement the transition by means of data exchange, open standards, and cooperation across the entire transport chain [28].

The Congress has definitely served as a global platform to showcase achievements in the field of high-speed rail and to promote technology exchange and industrial cooperation.

A number of countries, such as Japan, Spain, France, and Germany, have reached the point of saturation with high-speed rail services in their transport systems and therefore, naturally, they are reducing construction of new high-speed lines. China with its plans to build new HSR lines in 15–20 years to come will also reach this limit soon. The plans will, perhaps, be adjusted when a new range of speeds is achieved. As mentioned above, China is testing prospective trains with a design speed of 450 km/h and service speed of 400 km/h.

A common important trend in the railway industry worth mentioning is the growing robotics in many operation and maintenance activities. Both presentations and the exhibition presented ideas and ready-to-use solutions for these systems.

The Congress organizers promised to send all the presentations to the participants in September 2025. It is certainly very important to study the event proceedings, especially for those countries that have set out to implement their high-speed rail programmes in practice.

## REFERENCES

1. Münster Sebastian Cosmographiae uniuersalis lib. VI. in quibus, iuxta certioris fidei scriptorum traditionem describuntur, omniu[m] habitabilis orbis partiu[m] situs, p[ro]priæq[ue] dotes. regionum topographicæ effigies.: Basileæ, 1550 / *Cosmographiae uniuersalis lib. VI. in quibus, iuxta certioris fidei scriptorum traditionem describuntur, omniu[m] habitabilis orbis partiu[m] situs, p[ro]priæq[ue] dotes. regionum topographicæ effigies: Münster, Sebastian, 1489–1552.* Free Download, Borrow, and Streaming: Internet Archive.
2. *The Oxford Companion to British Railway History 1603–1990s.* Ed. by Jack Simmons & Gordon Biddle. Oxford University Press, 1997. 592 p.
3. *Stephenson's Rocket.* Science Museum Group. URL: <https://www.scienceandindustrymuseum.org.uk/what-was-on/stephensons-rocket>
4. Sokolova S.A. Increasing the Speed of Railways (Before the mid-19th century). History of Mechanical Engineering. *Proceedings of the Institute of History of Natural Science and Technology of the USSR.* Moscow: Publishing house of USSR Academy of Sciences, 1962;45.
5. Speed and High-Speed Rail Transport: Two Volumes. St. Petersburg: Vybor, 2001;1.
6. The Pioneer Zephyr (1934). URL: <https://corvidsketcher.com/2022/10/20/the-pioneer-zephyr-1934/>.
7. High-Speed Rail. General course: Study guide for railway university students. Kiselev I.P., Blazhko L.S., Bryn M.Ya. et al. Two Volumes. 2nd edition, revised and supplemented. Moscow, 2020;1.
8. Valinsky O.S., Kiselev I.P. Scientific support for the design and construction of high-speed rail lines. Timeline of developing competencies for high-speed rail in Russia. *Transport of the Russian Federation.* 2024;1(110):9-27.
9. High-speed worldwide. Historical, geographical and technological developments. UIC. Paris, 2025. 87 p.

10. High-Speed rail. Intercity and High-Speed. UIC. URL: <https://uic.org/passenger/highspeed/>.
11. Federal Law No. 448-FZ dated November 30, 2024 "On Amending Federal Law 'On railway transport in the Russian Federation. Kontur Normativ. URL: <https://normativ.kontur.ru/document?moduleId=1&documentId=483303>.
12. (Daily science and technology newspaper, January 03, 2025). URL: [http://www.china-railway.com.cn/xwzx/mtjj/kjrb/202501/t20250103\\_140450.html](http://www.china-railway.com.cn/xwzx/mtjj/kjrb/202501/t20250103_140450.html).
13. High Speed Lines in the World 2023 (Summary). Updated 1st December 2024. URL: [https://uic.org/IMG/pdf/20250618\\_high-speed\\_lines\\_summary.pdf](https://uic.org/IMG/pdf/20250618_high-speed_lines_summary.pdf)
14. Modern railway 2025. Exhibition Guide. July 8–10, 2025.
15. 全球最快高铁列车来了！CR450动车组样车发布 央视新闻 | 2024年12月29日 11:21:29 [The world's fastest high-speed rail train is coming! CR450 EMU sample car released CCTV News | December 29, 2024 11:21:29]. URL: <https://news.cctv.com/2024/12/29/ARTIbTsmXsQ0YrvKXrZ6vjIM241229.shtml>
16. 国家铁道试验中心环线刷新试验速度纪录 发布时间：2023-04-19来源 [National Railway Test Centre Loop Line Refresh Test Speed Record Release Time] 2023-04-19. URL: <https://www.chnrailway.com/index/shows?catid=10&id=4302>
17. 단독 시속 400km 초고속열차 도입 본격화...내년 초 마스터플랜 수립 [400 km per hour Super-fast train introduction in full swing...]. URL: <https://biz.heraldcorp.com/article/2318720>.
18. 최고시속 430km '해무' 타보니... "빠르고 안락하네". [Top speed: 430 km/h: Riding HEMU-430x... "Fast and comfortable"]. URL: <https://www.yna.co.kr/view/AKR20160406123800017>.
19. 次世代新幹線プロジェクトALFA-X [Next Generation Shinkansen Project ALFA-X] 2019. URL: <https://www.jreast.co.jp/recruit/career/special/future/alfa-x.html>.
20. Alfa-X Shinkansen: The 400 km/h Bullet Train 2020. URL: <https://www.jrailpass.com/blog/alfa-x-shinkansen-bullet-train>.
21. 时速400公里！全球最快高铁列车亮相。[400 kilometres per hour! The world's fastest high-speed train in the world is debut-
- ing]. URL: <https://www.zsnews.cn/news/index/view/cateid/37/id/743775.html>.
22. 时速400公里！全球最快高铁列车亮相。[400 kilometres per hour! The world's fastest high-speed train unveiled. Zhu Yan, Deputy Chief Engineer at CRRC Changke Co., Ltd., the manufacturer of the CR450BF]. URL: [https://www.gov.cn/yaowen/liebiao/202412/content\\_6995225.htm](https://www.gov.cn/yaowen/liebiao/202412/content_6995225.htm).
23. 全球最快、跑出全新试验速度 中国高铁再次冲上热搜 全球最快、跑出全新试验速度 中国高铁再次冲上热搜 [The world's fastest and new test speed, China's high-speed rail once again rushed to the hot search] 2025-07-10. URL: [https://content-static.cctvnews.cctv.com/snow-book/index.html?item\\_id=656653501519206742](https://content-static.cctvnews.cctv.com/snow-book/index.html?item_id=656653501519206742).
24. CR400BF-GS China EMU. URL: <https://www.china-emu.cn/Trains/Model/Detail-13123-101-S.html>.
25. 中国“八纵八横”高速铁路网 [China's "eight vertical and eight horizontal" high-speed railway network]. URL: <https://baike.baidu.com/item/%E4%B8%AD%E5%9B%BD%E2%80%9C%E5%85%AB%E7%BA%B5%E5%85%AB%E6%A8%AA%E2%80%9D%E9%AB%98%E9%80%9F%E9%93%81%E8%B7%AF%E7%BD%91/23742590>
26. 八纵八横”高铁网主通道建成投产约八成。 2024-10-02 [About 80% of the main channels of the "eight vertical and eight horizontal" high-speed rail network have been completed and put into operation]. URL: [https://www.gov.cn/yaowen/liebiao/202410/content\\_6978094.htm](https://www.gov.cn/yaowen/liebiao/202410/content_6978094.htm)
27. 中国高铁“八纵八横”规划图。（“当代中国”制图）。[China's "eight vertical and eight horizontal" high-speed railway network plan. (Map by "Modern China")]. URL: <https://www.ourchinastory.com/cn/8366/%E4%B8%80%E6%96%87%E7%9C%8B%E6%B8%85%E4%B8%AD%E5%9B%BD%E2%80%9C%E5%85%AB%E7%BA%B5%E5%85%AB%E6%A8%AA%E2%80%9D%E9%AB%98%E9%93%81%E7%BD%91%E7%BB%9C>
28. From vision to execution: Reflecting on the 12th UIC World Congress on High-Speed Rail. UIC. URL: <https://uic.org/com/enews/article/from-vision-to-execution-reflecting-on-the-12th-uic-world-congress-on-high>.

## ЛИТЕРАТУРА

1. Münster S. Cosmographiae uniuersalis lib. VI. in quibus, iuxta certioris fidei scriptorum traditionem describuntur, omniu[m] habitabilis orbis partiu[m] situs, p[ro]p[ri]a[et]q[ue] dotes. regionum topographicæ effigies.: Basileæ, 1550 / Cosmographiae uniuersalis lib. VI. in quibus, iuxta certioris fidei scriptorum traditionem describuntur, omniu[m] habitabilis orbis partiu[m] situs, p[ro]p[ri]a[et]q[ue] dotes. regionum topographicæ effigies: Münster, Sebastian, 1489–1552: Free Download, Borrow, and Streaming : Internet Archive.
2. The Oxford Companion to British Railway History 1603–1990s. / Ed. by Jack Simmons & Gordon Biddle. Oxford University Press, 1997. 592 p.
3. Stephenson's Rocket. Science Museum Group. URL: <https://www.scienceandindustrymuseum.org.uk/what-was-on/stephensons-rocket>
4. Соколова С.А. Повышение скоростей движения на железных дорогах (до середины XIX века). История машиностроения // Труды Ин-та истории естествознания и техники Акад. наук СССР. Т. 45. М.: Изд-во Акад. наук СССР, 1962.
5. Скоростной и высокоскоростной железнодорожный транспорт: в 2 т. Т. 1. СПб.: Выбор, 2001.
6. The Pioneer Zephyr (1934). URL: <https://corvidsketcher.com/2022/10/20/the-pioneer-zephyr-1934/>.
7. Высокоскоростной железнодорожный транспорт. Общий курс: учеб. пособие для студентов вузов железнодорожного транспорта / И.П. Киселев, Л.С. Блажко, М.Я. Брынь и др.: в 2 т. 2-е изд., перераб. и доп. Т. 1. М., 2020.
8. Валинский О.С., Киселев И.П. Научное обеспечение проектирования и строительства высокоскоростных железнодорожных магистралей. Хроника развития компетенций высокоскоростного железнодорожного транспорта в России // Транспорт РФ. 2024. № 1 (110), С. 9–27.
9. High-speed worldwide. Historical, geographical and technological developments. UIC. Paris, 2025. 87 p.
10. High-Speed rail. Intercity and High-Speed. UIC. URL: <https://uic.org/passenger/highspeed/>.
11. Federal Law No. 448-FZ dated November 30, 2024 "On Amending Federal Law 'On railway transport in the Russian Federation. Kontur Normativ. URL: <https://normativ.kontur.ru/document?moduleId=1&documentId=483303>.
12. 技日报：旅客、货物发送量等指标均创历史新高 我国铁路高质量发展交出亮眼成绩单 发布时间：2025-01-03 (Ежедневная научно-техническая газета. 3 января 2025). URL: [http://www.china-railway.com.cn/xwzx/mtjj/kjrb/202501/t20250103\\_140450.html](http://www.china-railway.com.cn/xwzx/mtjj/kjrb/202501/t20250103_140450.html).
13. High Speed Lines in the World 2023 (Summary). Updated 1st December 2024. URL: [https://uic.org/IMG/pdf/20250618\\_high-speed\\_lines\\_summary.pdf](https://uic.org/IMG/pdf/20250618_high-speed_lines_summary.pdf).
14. Modern railway 2025. Exhibition Guide. July 8–10, 2025.

15. 全球最快高铁列车来了！CR450动车组样车发布 央视新闻 | 2024年12月29日 11:21:29 [Приближается самый быстрый в мире скоростной железнодорожный поезд! Выпущен прототип мотор-вагонного электропоезда CR450 EMU Новости CCTV | 29 декабря] [The world's fastest high-speed rail train is coming! CR450 EMU sample car released CCTV News | December 29, 2024 11:21:29]. URL: <https://news.cctv.com/2024/12/29/ART1bTsmXsQ0YrvKXrZ6vjiM241229.shtml>

16. 国家铁道试验中心环线刷新试验速度纪录 发布时间：2023-04-19来源 [Кольцевая линия Национального испытательного центра железных дорог побила новый рекорд скорости испытаний] [National Railway Test Center Loop Line Refresh Test Speed Record Release Time] 2023-04-19. URL: <https://www.chnrailway.com/index/shows?catid=10&id=4302>

17. 단독 시속 400km 초고속열차 도입 본격화...내년 초 마스터 플랜 수립 [Полным ходом идет внедрение сверхскоростного поезда со скоростью 400 км в час...] [400 km per hour Super-fast train introduction in full swing...]. URL: <https://biz.heraldcorp.com/article/2318720>

18. 최고 시속 430km '해무' 타보니... "빠르고 안락하네" [Максимальная скорость – 430 км/ч. "Наему" Табони... «Быстро и комфортно»]. URL: <https://www.yna.co.kr/view/AKR20160406123800017>

19. 次世代新幹線プロジェクトALFA-X [Проект Синкансэн нового поколения ALFA-X] [Next Generation Shinkansen Project ALFA-X] 2019. URL: <https://www.jreast.co.jp/recruit/career/special/future/alfa-x.html>

20. Alfa-X Shinkansen: The 400 km/h Bullet Train [Alfa-X Shinkansen: сверхскоростной поезд со скоростью 400 км/ч] 2020. URL: <https://www.jrailpass.com/blog/alfa-x-shinkansen-bullet-train>

21. 时速400公里！全球最快高铁列车亮相 [400 километров в час! Дебютирует самый быстрый в мире высокоскоростной поезд]. URL: <https://www.zsnews.cn/news/index/view/cateid/37/id/743775.html>

22. 时速400公里！全球最快高铁列车亮相 [400 километров в час! Представлен самый быстрый в мире высокоскоростной поезд. Чжу Янь, заместитель главного инженера компании CRRC Changke Co., Ltd., производителя электропоезда

CR450BF]. URL: [https://www.gov.cn/yaowen/liebiao/202412/content\\_6995225.htm](https://www.gov.cn/yaowen/liebiao/202412/content_6995225.htm)

23. 全球最快、跑出全新试验速度 中国高铁再次冲上热搜 全球最快、跑出全新试验速度 中国高铁再次冲上热搜 [Китайская высокоскоростная железная дорога, ставшая самой быстрой и новой в мире в тестовом режиме, в очередной раз бросилась в горячие поиски] [The world's fastest and new test speed, China's high-speed rail once again rushed to the hot search] 2025-07-10. URL: [https://content-static.cctvnews.cctv.com/snow-book/index.html?item\\_id=656653501519206742](https://content-static.cctvnews.cctv.com/snow-book/index.html?item_id=656653501519206742)

24. CR400BF-GS ChanaEMU. URL: <https://www.china-emu.cn/Trains/Model/Detail-13123-101-S.html>

25. 中国“八纵八横”高速铁路网 [Китайская сеть высокоскоростных железных дорог «восемь вертикалей и восемь горизонталей»] [China's "eight vertical and eight horizontal" high-speed railway network]. URL: <https://baike.baidu.com/item/%E4%B8%AD%E5%9B%BD%E2%80%9C%E5%85%AB%E7%BA%B5%E5%85%AB%E6%A8%AA%E2%80%9D%E9%AB%98%E9%80%9F%E9%93%81%E8%B7%AF%E7%BD%91/23742590>

26. 八纵八横”高铁网主通道建成投产约八成。2024-10-02 [Около 80% основных каналов высокоскоростной железнодорожной сети «восемь вертикальных и восемь горизонтальных» уже завершены и введены в эксплуатацию] [About 80% of the main channels of the "eight vertical and eight horizontal" high-speed rail network have been completed and put into operation]. URL: [https://www.gov.cn/yaowen/liebiao/202410/content\\_6978094.htm](https://www.gov.cn/yaowen/liebiao/202410/content_6978094.htm)

27. 中国高铁“八纵八横”规划图。(“当代中国”制图) [План строительства высокоскоростной железной дороги в Китае «Восемь вертикалей и восемь горизонталей». (Картография «Современного Китая»]. URL: <https://www.ourchinastory.com/cn/8366/%E4%B8%80%E6%96%87%E7%9C%8B%E6%B8%85%E4%B8%AD%E5%9B%BD%E2%80%9C%E5%85%AB%E7%BA%B5%E5%85%AB%E6%A8%AA%E2%80%9D%E9%AB%98%E9%93%81%E7%BD%91%E7%BB%9C>

28. From vision to execution: Reflecting on the 12th UIC World Congress on High-Speed Rail. UIC. URL: <https://uic.org/com/enews/article/from-vision-to-execution-reflecting-on-the-12th-uic-world-congress-on-high>

## Bionotes

**Igor P. Kiselev** — Cand. Sci. (Philos.), Dr. Sci. (His.), Professor of the Department of “History, Philosophy, Political Science and Sociology”, transport engineer; **Emperor Alexander I St. Petersburg State Transport University (PGUPS)**; Chief Science Editor; **Journal “BRICS Transport”**; 9 Moskovsky pr., St. Petersburg, 190031, Russian Federation; SPIN-code: 4347-9926, ID RSCI: 541415, Scopus: 57220864567; [kis1347@mail.ru](mailto:kis1347@mail.ru).

## Об авторе

**Игорь Павлович Киселев** — кандидат философских наук, доктор исторических наук, профессор кафедры «История, философия, политология и социология», инженер путей сообщения; **Петербургский государственный университет путей сообщения Императора Александра I (ПГУПС)**; главный научный редактор; журнал «Транспорт БРИКС»; 190031, г. Санкт-Петербург, Московский пр., д. 9; главный научный редактор; SPIN-код: 4347-9926, РИНЦ ID: 541415, Scopus: 57220864567; [kis1347@mail.ru](mailto:kis1347@mail.ru).

The author declares no conflicts of interests.

Автор заявляет об отсутствии конфликта интересов.

The article was submitted 21.07.2025; accepted for publication 28.08.2025.

Статья поступила в редакцию 21.07.2025; принята к публикации 28.08.2025.

Review information article

UDC 629.4.015

doi: 10.46684/2025.3.02

EDN BUYFAZ

## Engineering of an electric train for the first phase of the high-speed railway network in Russia

Vladimir E. Andreev

Department of Technical Policy of JSC Russian Railways; Moscow, Russian Federation; info@rzd.ru

**ABSTRACT** Creating Russia's first high-speed railway line between Moscow and St. Petersburg is an important socio-political, complex engineering and technical, as well as major economic project.

In addition to the design and construction of fixed track, power supply, automation, telecontrol and telecommunication facilities and other infrastructure components, the project includes, in a single package, the design and commercial production of a Russian-made high-speed train. In 2025, the *BRICS Transport* (vol. 4, issues 1 and 2) published the Report on the plenary session of the VI Betancourt International Engineering Forum "High-speed railway line St. Petersburg–Moscow: Challenges, solutions, personnel" in both Russian and English. The Report presented the background of the project and its infrastructure component. To complete the picture, we are publishing the slightly abridged presentation "On engineering of an electric train for the first phase of the high-speed railway network in Russia" made by Head of the Department of Technical Policy of JSC Russian Railways, Candidate of Engineering Sciences Vladimir E. Andreev for students and professors of Emperor Alexander I St. Petersburg State Transport University on April 2, 2025.

**KEYWORDS:** high-speed railway rolling stock; train; railway coach; bogie; power supply system; brake system; travel conditions; passenger comfort

**For citation:** Andreev V.E. Engineering of an electric train for the first phase of the high-speed railway network in Russia. *BRICS transport*. 2025;4(3):02. <https://doi.org/10.46684/2025.3.02>. EDN BUYFAZ.

Информационная статья

## Разработка электропоезда для первого этапа сети высокоскоростных магистралей в России

В.Е. Андреев

Департамент технической политики ОАО «РЖД»; г. Москва, Россия; info@rzd.ru

**АННОТАЦИЯ** Создание первой в стране высокоскоростной железнодорожной магистрали Москва – Санкт-Петербург – важный социально-политический, сложный технический, технологический и большой экономический проект.

Проект комплексно включает, помимо проектирования и строительства стационарных объектов путевого хозяйства, электроснабжения, автоматики, телемеханики и связи и других инфраструктурных компонентов, разработку и освоение производства отечественного высокоскоростного поезда. В журнале «Транспорт БРИКС» в 2025 году (т. 4, вып. 1 и 2) на русском и английском языках был опубликован репортаж-отчет о пленарном заседании VI Бетанкуровского международного инженерного форума «Высокоскоростная железнодорожная магистраль Санкт-Петербург – Москва: вызовы, решения, кадры», в котором были представлены основные сведения о проекте, его инфраструктурной составляющей. Для полноты картины с небольшими сокращениями публикуется лекция-доклад начальника Департамента технической политики ОАО «РЖД», к.т.н. В.Е. Андреева «О разработке электропоезда для первого этапа сети высокоскоростных магистралей в России», прочитанный 2 апреля 2025 г. для студентов и преподавателей Петербургского государственного университета путей сообщения Императора Александра I.

**КЛЮЧЕВЫЕ СЛОВА:** высокоскоростной железнодорожный подвижной состав; поезд; вагон; тележка; система электропитания; тормозная система; условия проезда; комфорт пассажиров

**Для цитирования:** Андреев В.Е. Разработка электропоезда для первого этапа сети высокоскоростных магистралей в России // Транспорт БРИКС. 2025. Т. 4. Вып. 3. Ст. 02. <https://doi.org/10.46684/2025.3.02>. EDN BUYFAZ.

© Vladimir E. Andreev, 2025

© Translation into English "BRICS Transport", 2025

## BASIC CHARACTERISTICS OF THE HIGH-SPEED TRAIN

To operate on high-speed lines electrified with 25 kV 50 Hz alternating current and high-speed lines electrified with 3 kV direct current as the first phase of the high-speed railway network, a dual-voltage electric train consisting of eight coaches (Fig. 1, 2) with a design speed of 360 km/h will be built in Russia. The trains will be designed to operate in the environments with outside air temperatures from  $-40^{\circ}\text{C}$  to  $+40^{\circ}\text{C}$ . It will be possible to operate them in double train sets of 16 coaches with multiple-unit (MU) control.

The preparation of the working design documentation for the main train components, including the body, bogies, traction, brake and other systems is currently underway (Fig. 3).

The engineering documentation is being worked out by the specially created Engineering Centre for Railway Transport JSC established in 2019. Its current shareholders are Russian Railways JSC, the Government of Moscow, and Sinara Group JSC<sup>1</sup>. The Centre's activities are aimed at solving relevant engineering problems and implementing knowledge-intensive projects in the field of railway transport. Engineering of high-speed passenger rolling stock is a pilot one.

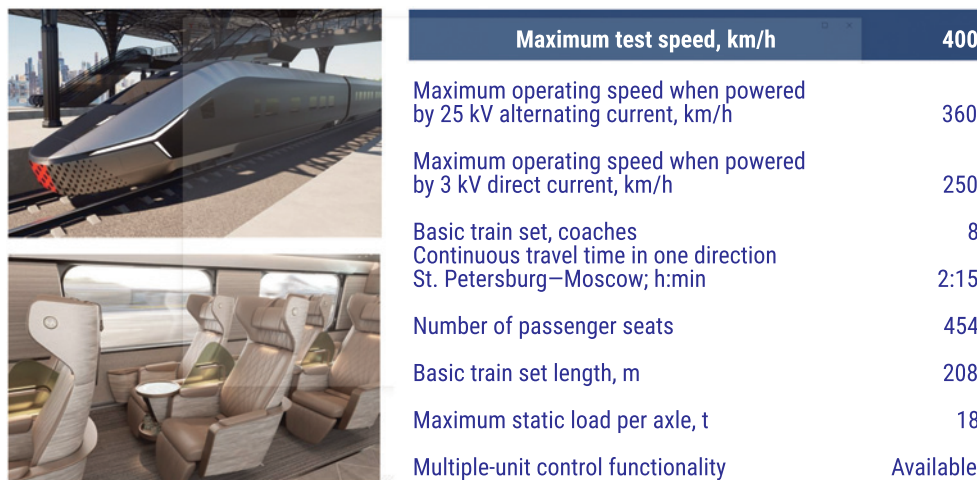

Fig. 1. Exterior design of the driving trailer; interior of the first-class compartment, and basic specifications of the train



Fig. 2. Basic systems, components, units and assemblies of the train

<sup>1</sup> Sinara Group JSC is a Russian multi-industry holding company operating in transport engineering, financial services, etc. Their head office is based in Yekaterinburg.



Fig. 3. Organizations involved in the train engineering and production

The development and manufacture of the high-speed electric train and its component parts involve more than 150 Russian transport engineering companies and eight research centres.

### MAIN TECHNICAL AND ENGINEERING SOLUTIONS FOR THE RUSSIAN HIGH-SPEED TRAIN

The engineering documentation is worked out in strict compliance with the schedule agreed upon by all the parties on the basis of the Technical Specifications for the Electric Train approved by Russian Railway JSC on December 9, 2020. The documentation is worked out along with a set of research studies on relevant issues to substantiate the standards and select sound engineering solutions.

The project will for the first time provide Russia with the following technologies and technical solutions (Fig. 4, 5):

- New friction materials for the friction pair in the braking system (brake shoes and brake discs) that can effectively perform at high speeds in all climate environments;
- LTE-based railway radio communication systems;
- New generation high-speed electric motors and traction gearboxes;
- An open-architecture hardware and software platform for building an electric train control system;
- Combined automatic couplers and coupling devices;
- Inter-carriage gangways with outer bellows for better aerodynamic performance;
- Underframe, bogies, and traction drive;
- Spring bases.

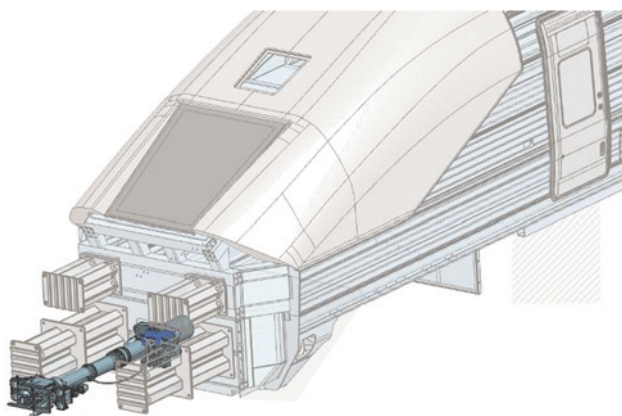

Fig. 4. Head carriage body nose elements: damper and fairing

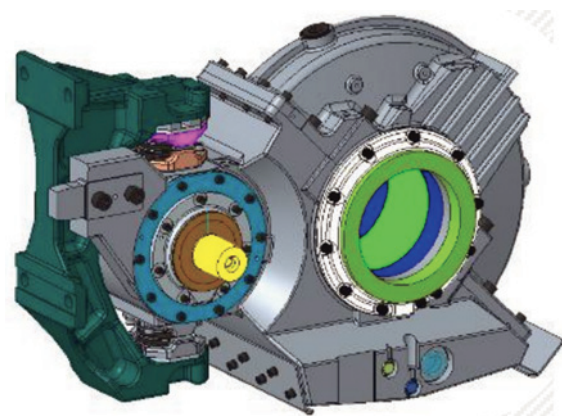

Fig. 5. Traction gearbox

The manufacturers of the component parts and sub-systems of the train have been set the task to use advanced materials and technology to ensure high reliability and the smallest possible weight and dimensions of the products.

The first prototypes of parts and assemblies for the electric train were manufactured in the second half of 2024. The first frame of the trailer bogie is being tested to destruction in order to determine the limit loads. The bulk of prototypes will be manufactured in 2025.

**LAYOUT AND PASSENGER TRAVEL CLASSES**

The eight-coach electric train will have four passenger service classes: First Class, Business, Comfort, and Standard coaches. This will allow to offer transportation services to passengers providing a wide range of comfort levels based on their budget (Fig. 6-17). The total capacity of the eight-coach train set is 454 passengers.

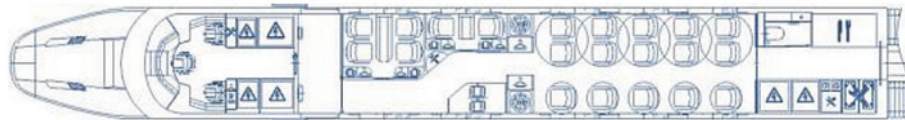

Fig. 6. Layout of First Class seats and compartments in Coach 1 (a driving trailer)



Meeting room compartment:  
4 seats; and suite compartment: 2 seats

Fig. 7. Meeting room compartment in Coach 1



First Class: 15 seats

Fig. 8. Interior of the First Class passenger compartment in Coach 1



Fig. 9. Layout of Business seats in Coach 2



Fig. 10. Layout of Comfort seats in Coach 3



Comfort: 230 seats

Fig. 11. Interior of the Comfort passenger compartment

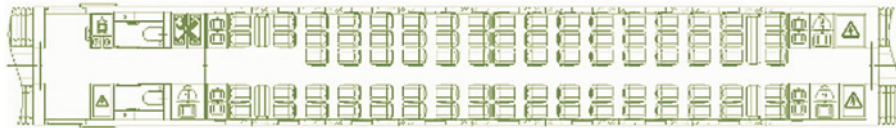

Fig. 12. Layout of Standard seats in Coach 4



Fig. 13. Interior of the Standard passenger compartment

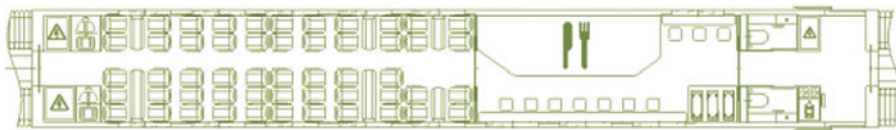

Fig. 14. Layout of Standard seats in Coach 5 with a bar

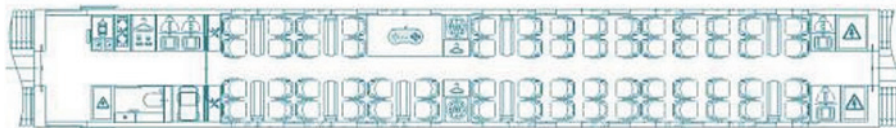

Fig. 15. Layout of Comfort seats in Coach 6 and areas with wheelchairs securement systems for people with disabilities



Fig. 16. Layout of Comfort seats in Coach 7

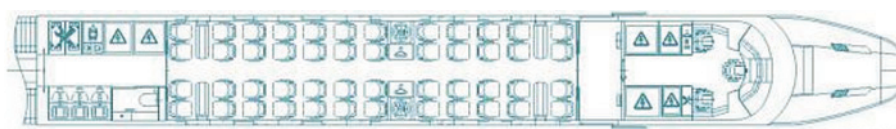

Fig. 17. Layout of Comfort seats in Coach 8 (a driving trailer)

The design of the electric train will be in line with the world's modern engineering and artistic trends and materials taking into account the experience of operating the Sapsan train and passenger demands.

In Standard coaches, it was decided to use the "2+3" seating arrangement (two seats – aisle – three seats).

Coach 1 has two compartments: a four-person meeting room compartment and a two-person luxury

compartment. In Coach 1, the First Class seats are arranged in "2+1" configuration. The power-assisted design of the seats equipped with electric drives enables the passengers to convert them into a sleeping berth. Passengers in Coaches 1 and 2 will be offered individual service and will be served food and drinks at their seats. For this purpose, Coach 1 has a mini-kitchen and serving equipment.

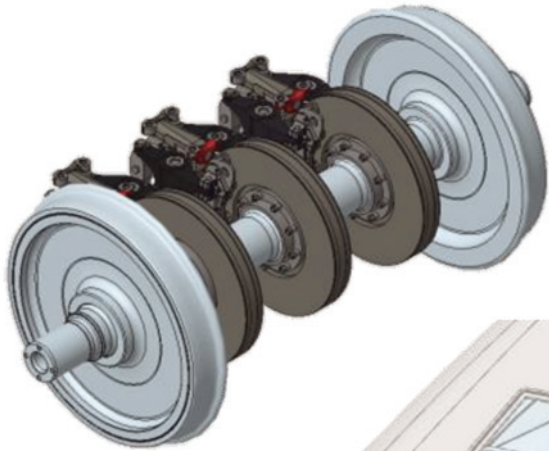

**Fig. 18.** Elements of the braking system on the axle of the carrier bogie: brake discs and calliper brake assemblies

Coach 2 has seats for Business class passengers with “2+2” seating arrangement in a row. The seats are also convertible. Coaches 3, 6 and 8 are intended for Comfort class passengers and have “2+2” seating configuration in a row.

Coach 3 has the train master’s compartment. It is also equipped with special systems for placing and securing wheelchairs and thus can accommodate wheelchair-bound passengers.

Coach 6 has a play area for children. Coaches 4 and 5 are designed for Standard class passengers and have “3+2” seating arrangement in a row. Coach 5 has a bar area with a kitchen which is accessible to all passengers on the train.

## TRAIN BRAKING SYSTEM

The main solutions being prerequisite for the implementation of a high-speed electric train project involve designing the vital systems: the traction and braking systems of the train, and train protection systems.

The braking system is a very important component of the electric train. The project places a particular focus on the creation of necessary equipment for the full cycle of tests. It is necessary to select materials for the friction pair of the disc brake (disc — brake shoe). Until now, Russia did not produce necessary materials for the friction elements of braking devices that could operate at speeds of up to (and including) 400 km/h, and there was no technology for manufacturing them (Fig. 18, 19).

The existing brake test rigs in Russia allow for simulating the operation of brakes at speeds of up to 250–300 km/h, but their capability for simulating operating conditions with high braked weight values is limited.

To address these challenges, arrangements have been made to develop a technology and manufacture a relevant brake friction test setup at the facilities of the Railway Research Institute (VNIIZhT), where the parameters of the disc brake friction pair will be determined and necessary tests will be conducted in 2025–2026.

36 new sub-systems comprising 10,000 components, parts and assemblies will be developed for the high-speed electric train. All train elements will be manufactured in Russia.

Most systems and components are subject to high requirements to weight, dimensions, reliability, and life cycle costs. The implementation of the project will enable many designers and manufacturers of component parts to move to a qualitatively new technology level. At least one manufacturer was identified for all essential systems and components, and several manufacturers were selected for many of them. Technical specifications have been developed and approved for all components of the electric train.

The manufacturer of the electric train is the Ural Locomotives Plant (Ural Locomotives LLC) located in Verkhnyaya Pyshma, Sverdlovsk Region. They will manufacture the essential components (bogies and carriage bodies) and will provide complete assembly,



a

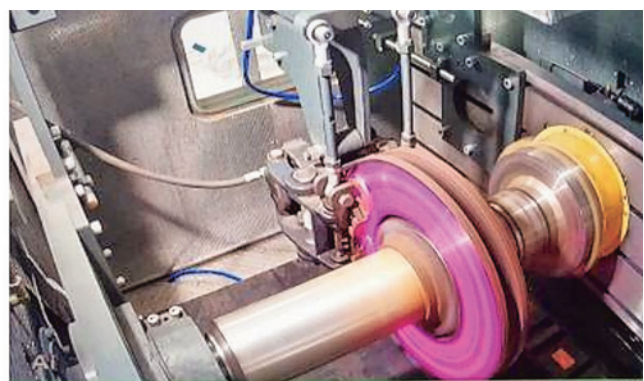

b

**Fig. 19:** a – General view of the testing facility for braking equipment; b – Test unit for brake discs and brake assembly



**Fig. 20.** General view of the production buildings of the Ural Locomotives Plant<sup>2</sup>

adjustment and certification of the train (Fig. 20). New assembly workshops are under construction on the premises of the plant.

Other project participants are member companies of Transmashholding Group. They will design and manufacture six electric train systems (components and devices for the inter-carriage gangway, external doors, ventilation and air conditioning systems, internal doors, lighting systems, and interior elements).

## CONCLUSION

The implementation of the project that is so important for the country will use the full weight of intellectual, technological and financial resources. The project for creating a high-speed electric train and building the first high-speed railway line is given special attention by the Russian President, the Government of the Russian Federation, the Government of Moscow, the Ministry of Industry and Trade of Russia, the Ministry of Transport of Russia, other ministries and departments, and Russian Railways JSC. The transport engineering companies engaged in the implementation of the project receive comprehensive support from these entities.

The implementation of such an ambitious project will allow the country's industrial sector to acquire new competencies that will both contribute to the creation of a Russian high-speed train and help improve the quality of locomotives, carriages and railway infrastructure systems manufactured in the country. Russian Railways Holding will gain unique competencies in the development of a high-speed train and its components, technologies and design procedures, modeling and testing. This will make it possible to create new types of rolling stock in the future.

## Bionotes

**Vladimir E. Andreev** — Cand. Sci. (Tech.), Head of the Department of Technical Policy of JSC Russian Railways; **JSC Russian Railways**; 1 bld., 2/1, Novaya Basmannaya st., Moscow, 107174, Russian Federation; info@rzd.ru.

## Об авторе

**Владимир Евгеньевич Андреев** — кандидат технических наук, начальник Департамента технической политики; ОАО «РЖД»; 107174, Россия, г. Москва, Новая Басманная ул., 2/1, стр. 1; info@rzd.ru.

The author declares no conflicts of interests.

Автор заявляет об отсутствии конфликта интересов.

The article was submitted 06.08.2025; accepted for publication 30.08.2025.

Статья поступила в редакцию 06.08.2025; принята к публикации 30.08.2025.

<sup>2</sup> <https://opzt.ru/news/ooo-uralskie-lokomotivy-ispolnilos-10-let/>

Original article

UDC / УДК 629.454.021  
doi: 10.46684/2025.3.03  
EDN BWOOTX

## Development of an improved design of a high-capacity passenger railcar for the railways of Uzbekistan

Rustam V. Rahimov<sup>1✉</sup>, Farida S. Galimova<sup>2</sup>, Diyor Sh. Zafarov<sup>3</sup>

<sup>1,2,3</sup> Tashkent State Transport University, Uzbekistan, Tashkent

<sup>1</sup> rakhimovrv@yandex.ru✉; <https://orcid.org/0000-0002-5652-2604>

<sup>2</sup> farida.galimova.2020@inbox.ru; <https://orcid.org/0000-0002-4919-2061>

<sup>3</sup> textmeback117@gmail.com; <https://orcid.org/0000-0003-0100-4815>

**ABSTRACT** In the context of the rapid growth of passenger traffic by rail, one of the priorities is to increase the efficiency of rolling stock use. The key direction in solving this problem is to increase the passenger capacity of railway coaches while ensuring a high level of their structural strength, reliability and safety. This study presents an improved design of the body of a passenger coach with increased capacity, developed taking into account modern requirements for comfort, environmental friendliness and operational efficiency. To assess the design characteristics, a comprehensive analysis was carried out, including theoretical calculations of the stress-strain state of the body elements using the finite element method. Numerical modeling made it possible to identify critical areas of the structure and optimize its parameters to increase strength and reduce material consumption. The simulation results were supplemented and confirmed by experimental tests of the prototype, conducted in conditions as close as possible to real operation. The data obtained indicate that the design meets the requirements of current regulatory documents, including safety and durability standards. The proposed design demonstrates improved operational characteristics, which makes it promising for use in the design and modernization of new-generation passenger coaches. The research results can serve as a basis for further developments in the field of innovative railway transport, providing an increased level of comfort and efficiency.

**KEYWORDS:** passenger railcar; passenger capacity; design; frame; stress; strength; testing

**For citation:** Rahimov R.V., Galimova F.S., Zafarov D.Sh. Development of an improved design of a high-capacity passenger railcar for the railways of Uzbekistan. *BRICS transport*. 2025;4(3):03. <https://doi.org/10.46684/2025.3.03>. EDN BWOOTX.

Научная статья

## Разработка усовершенствованной конструкции пассажирского вагона увеличенной вместимости для железных дорог Узбекистана

Р.В. Рахимов<sup>1✉</sup>, Ф.С. Галимова<sup>2</sup>, Д.Ш. Зафаров<sup>3</sup>

<sup>1,2,3</sup> Ташкентский государственный транспортный университет, Узбекистан, г. Ташкент

<sup>1</sup> rakhimovrv@yandex.ru✉; <https://orcid.org/0000-0002-5652-2604>

<sup>2</sup> farida.galimova.2020@inbox.ru; <https://orcid.org/0000-0002-4919-2061>

<sup>3</sup> textmeback117@gmail.com; <https://orcid.org/0000-0003-0100-4815>

**АННОТАЦИЯ** В условиях стремительного роста объемов пассажирских перевозок по железной дороге одной из приоритетных задач становится повышение эффективности использования подвижного состава. Ключевое направление в ее решении – увеличение пассажироваместимости вагонов при обеспечении высокого уровня прочности, надежности и безопасности конструкции.

Представлена усовершенствованная конструкция кузова пассажирского вагона повышенной вместимости, разработанная с учетом современных требований к комфорту, экологичности и эксплуатационной эффективности. Для оценки характеристик конструкции был проведен комплексный анализ, включающий теоретические расчеты напряженно-деформированного состояния элементов кузова с использованием метода конечных элементов. Численное моделирование позволило выявить критические зоны конструкции и оптимизировать ее параметры для повышения прочности и снижения материалоемкости. Результаты моделирования были дополнены и подтверждены экспериментальными испытаниями опытного образца, проведенными в условиях, максимально приближенных к реальной эксплуатации.

Полученные данные свидетельствуют о соответствии конструкции требованиям действующих нормативных документов, включая стандарты безопасности и долговечности. Предложенная конструкция демонстрирует улучшенные эксплуатационные характеристики, что делает ее перспективной для применения в проектировании и модернизации пассажирских вагонов нового поколения. Результаты исследования могут служить основой для дальнейших разработок в области создания инновационного железнодорожного транспорта, обеспечивающего повышенный уровень комфорта и эффективности.

**КЛЮЧЕВЫЕ СЛОВА:** пассажирский вагон; пассажироваместимость; конструкция; рама; напряжения; прочность; испытания

**Для цитирования:** Рахимов Р.В., Галимова Ф.С., Зафаров Д.Ш. Разработка усовершенствованной конструкции пассажирского вагона увеличенной вместимости для железных дорог Узбекистана // Транспорт БРИКС. 2025. Т. 4. Вып. 3. Ст. 03. <https://doi.org/10.46684/2025.3.03>. EDN BWOOTX.

## INTRODUCTION

As the network of railway routes expands and modern railway lines are put into operation, there is a growing need for streamlining passenger services. The major task is to make the most of resources of the passenger services system, while necessarily providing proper and safe conditions for meeting people's needs<sup>1</sup>.

A viable solution is to purchase rolling stock abroad or localize its production in the Republic of Uzbekistan, with the latter being a better option in the long run. Since 2009, the Tashkent Plant for Construction and Repair of Passenger Carriages Joint-Stock Company (TVSRZ JSC) has been manufacturing 61-907 wagons<sup>2</sup> which have been used as a basis for modifications, such as sleepers, special-purpose carriages, and Class I (Business), II (VIP) and III (Economy) coaches [1, 2].

To improve the performance of passenger services, it is important to expand the capacity of coaches, increase train speeds, and reduce costs per passenger. As international experience shows, this can be achieved by using long-wheelbase or double-deck coaches [3–5]. However, double-deckers have a number of design constraints, such as high weight, complex design, high costs, and incompatibility with the current railway infrastructure in the Republic of Uzbekistan.

A number of comprehensive studies are currently underway to assess the structural strength and fatigue durability of the body frame of passenger coaches.

A special focus is put on analysing the stress-strain state of structural elements under various operational loads [6–8]. They examine the causes of possible malfunctions and defects that can affect the structural reliability and safety in the long run [9]. Research and development projects create numerical and computer models of coach bodies that allow for high-precision computations using the finite element method. These models help identify critical stress concentration areas, optimize geometry of load-bearing elements, and predict the service life of the structure under various modes of operation [10–15]. This approach is necessary to develop modern higher-capacity passenger coaches that meet current requirements for strength, reliability and safety.

Thus, at the first stage it was decided to develop a long-wheelbase coach in line with traffic safety and good performance requirements.

The purpose of the study is to develop engineering solutions for the design of a high-capacity passenger coach geared to the conditions in the Republic of Uzbekistan.

## SUBJECT OF THE STUDY

The subject of this study is the design of the body of a 61-907 open-space coach built by TVSRZ JSC which can carry 48 passengers [16].

<sup>1</sup>Resolution of the President of the Republic of Uzbekistan No. PP-28 dated January 27, 2025 “On measures for further development of the transport and logistics system in the Republic of Uzbekistan”.

<sup>2</sup>TU 17923832-013. 61-907 passenger compartment coaches with air conditioning. Tashkent. JSC “TVSRZ”. 2022:41.

## THEORETICAL RESEARCH

For the purposes of theoretical research, a 3D simulation model of the coach body was designed in SolidWorks automated design system (version 2021). The model was then exported to ANSYS Workbench (version 2021), where a refined finite-element model (FEM) was created on its basis. A strength analysis using FEM was conducted in accordance with Standards [9] and the State Standard (GOST) 34093-2017 [10]. The developed FEM made it possible to determine the stress-strain state of the structure under static and dynamic loads. To analyse stresses and identify areas that require reinforcement, the model included cross-sections with virtual measurement points, which helped obtain local stress values and perform a detailed analysis of the stress loading on the body.

The computations produced maximum stress values at virtual measurement points. The distribution diagrams for equivalent Von Mises stresses arising from a longitudinal force of 2.5 MN (compression) are shown in Fig. 1.

An analysis of the resulting dependencies of maximum stresses arising in elements of the coach body has shown that an increase in longitudinal loads produces insignificant changes in stress in areas of the side and end walls, as well as of the roof; however, in certain parts of the carriage frame elements, stresses exceed the permissible values, which indicates that these areas require improvement in terms of design. In this connection, further research was focused directly on the design of the carriage frame. The study included further calculations where the length of the carriage was incrementally increased in the range from 500 to 2,500 mm with a 500 mm increment. The distribution diagrams for equivalent Von Mises stresses in frame elements from longitudinal forces are shown in Fig. 2.

Thus, when the carriage length is increased by 2,500 mm, the maximum equivalent stresses reach 688.75 MPa in the centre sill and 661.13 MPa in the side sills, which significantly exceeds the permissible value of 293.25 MPa. This means that the frame needs to be structurally reinforced in order to ensure safe operation and increase the capacity of an extended coach.

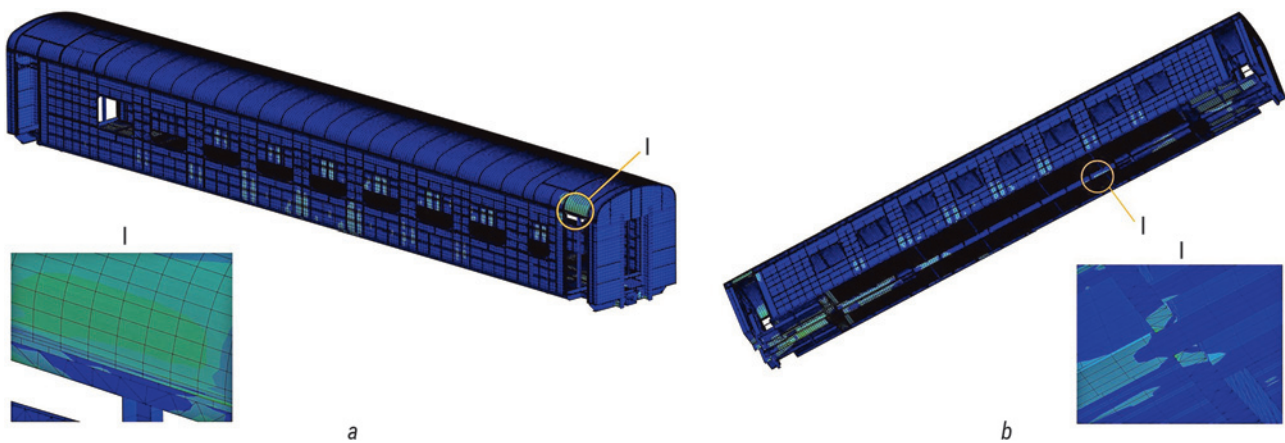

Fig. 1. Distribution field of equivalent stresses (Von Mises stress) in the coach body under the action of a longitudinal compressive force of 2.5 MN: *a* – top view; *b* – bottom view

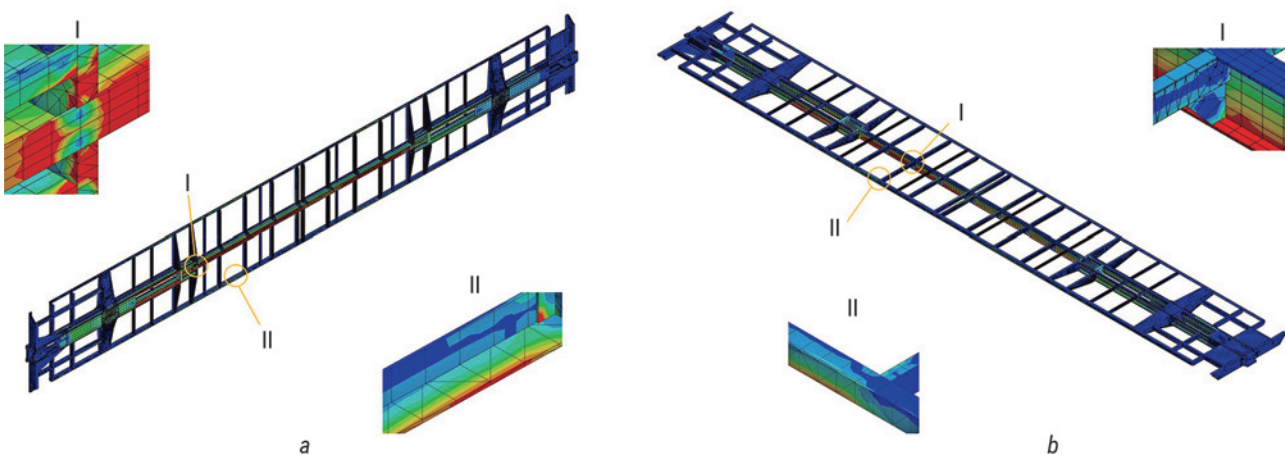

Fig. 2. Distribution fields of equivalent stresses in frame elements from longitudinal forces: *a* – top view; *b* – bottom view

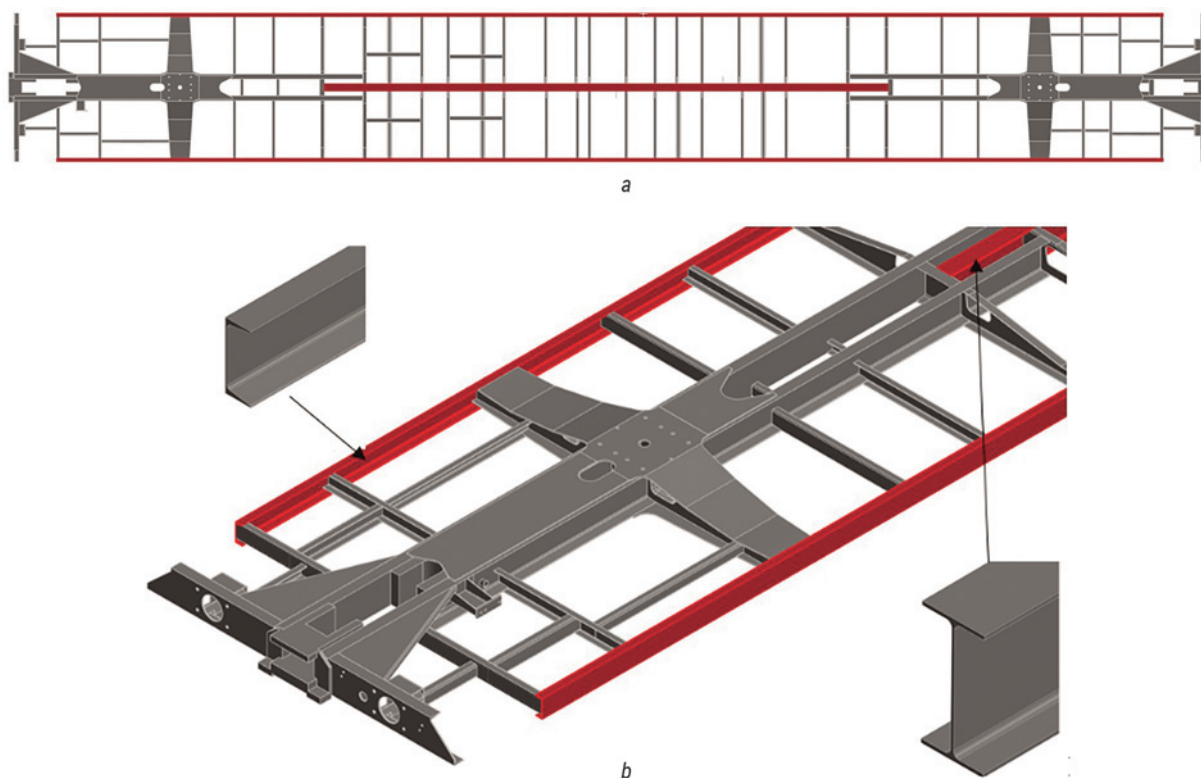

Fig. 3. Frame of an extended coach with reinforcement parts: *a* – general view; *b* – reinforced elements (centre sill and side sills)

The desktop study has shown that in order to meet structural strength requirements, the width of beam flanges in the middle section of the centre sill of the frame made of an I-beam No. 30 should be increased from 135 mm to 150 mm. In addition, to improve the structural strength, it is recommended to use C-channels No. 18 as the side sills to replace the original L-bars. It has been found that with a wheelbase extended to 18,000 mm and a 1,500 mm longer overall length,

the coach design meets the requirements for automatic coupling. The improved design of the carriage frame is shown in Fig. 3.

After validating the chosen parameters for the extended coach design, stress was calculated in accordance with the requirements<sup>3</sup> for three design conditions<sup>4</sup> using the software package for FEM analysis and numerical modelling. The calculation results are given in Table 1.

Table 1

Stresses in elements of the extended coach body

Structural element	Design conditions		
	I	II	III
Frame elements	219 MPa (74% of the permissible value)	237 MPa (80% of the permissible value)	96 MPa (51% of the permissible value)
Side wall framework elements	135 MPa (46% of the permissible value)	117 MPa (40% of the permissible value)	107 MPa (56% of the permissible value)
End wall framework elements	114 MPa (39% of the permissible value)	97 MPa (33% of the permissible value)	39 MPa (21% of the permissible value)
Roof framework elements	128 MPa (44% of the permissible value)	117 MPa (40% of the permissible value)	105 MPa (55% of the permissible value)

<sup>3</sup> Standards for the calculation and design of new and upgraded 1,520 mm gauge (non-self-propelled) carriages on railways of the Ministry of Railways. Effective October 01, 1984. Moscow. VNIIV-VNIIZhT. 1983:260.

<sup>4</sup> GOST 34093-2017. Passenger cars on locomotive traction. Requirements for structural strength and dynamic qualities. Moscow. Standartinform. 2017:45.

Table 2

Stability safety factors for coach body elements

Design conditions	Buckling failure zone	Stability factor	
		design	permissible
I (compression)	Floor sheet at the tail end of the carriage	2.22	1.1
I (impact)	Floor sheet at the tail end of the carriage	2.75	1.1
II (tensile)	Roof covering in the middle part of the carriage	2.90	1.3
II (jerk)	Roof covering at the tail end of the carriage	2.38	1.3
III (compression)	Floor sheet at the tail end of the carriage	1.61	1.5
III (tensile)	Corrugated sheets of the floor	2.29	1.5

Thus, in all the design conditions, the values of stress in elements are within the permissible limits, which confirms that the structure is structurally safe in terms of its strength.

The stability of elements of the extended body was assessed using the estimated safety factors.

The results summarized in *Table 2* have shown a sufficient safety margin and conformity of the design to standards.

## STATIC AND DYNAMIC PERFORMANCE TESTING

For the purposes of experimental evaluation of the developed extended coach design, a preproduction prototype was fabricated and subject to static and dynamic performance testing<sup>5</sup>.

The purpose of the static tests was to assess the stress-strain state of elements of the body metal structures at the reference points upon the exposure to statically applied compression and tensile loads.

The product was tested at the facilities of TVSRZ JSC. A special static loading fixture for carriages was used to create longitudinal forces. Deformations were registered using resistive strain gauges connected to a MIC-185 measuring and computing system and the measurement processes were recorded with a personal computer. Before the tests, strain gauges correspond-

ing to the most heavily loaded sections identified by the preliminary FEM calculations were glued at the predetermined reference points of load-bearing body elements. The tests involved applying a static longitudinal force of 1.5 MN (tensile) and 2.5 MN (compression) via automatic coupler elements with the use of jacks installed on a loading fixture.

As a result of the static tests of the extended coach prototype, the maximum stress reached 230.1 MPa in the central part of the centre sill and 83.1 MPa in the side sill, which does not exceed the permissible level of 293.25 MPa.

At the next stage, the extended carriage prototype underwent dynamic tests on the Tukimachi-Angren section. The following results were registered: vertical dynamics coefficient: 0.24 (with the design and permissible values being 0.21 and 0.35, respectively); stability factor against wheel derailment: 2.1 (design and permissible values: 2.7 and 2.0, respectively); and stability against overturning: 3.13 (design and permissible values: 1.92 and 1.4, respectively). As a result, the dynamic reliability of the design was confirmed.

Testing the impact of the extended coach on the railway track according to GOST 34759-2021 has confirmed that the track strength characteristics meet regulatory requirements for the operation of the coach. The tests were conducted at a temperature of 26–36 °C, humidity of 16–30 %, and a pressure of 100.2 kPa.

The developed design increases the passenger capacity compared to the base model (48 seats). In Class I and II extended coaches, the number of seats was increased by 50 % to reach 72 seats, and in Class III coaches, it was increased by 87 % to 90 seats.

## CONCLUSION

Thus, the research has shown the effectiveness of the structural solutions designed to increase the passenger capacity while maintaining the levels of the carriage strength and safety. The modelling and testing have shown that the developed extended design of the body with a reinforced frame meets regulatory requirements. The comprehensive approach confirmed the soundness of the design in terms of strength and dynamic performance. The optimized interior layout made it possible to increase the number of seats to 72 (Classes I–II) and 90 (Class III), contributing to better cost-effectiveness of passenger services. The design has been successfully adapted to being manufactured by TVSRZ JSC and to the operating conditions in the Republic of Uzbekistan.

<sup>5</sup> GOST 33788-2016. Freight and passenger railcars. Methods of testing structural strength and dynamic performance. Moscow. Standartinform. 2016:41.

## REFERENCES

1. Boronenko Yu.P., Rahimov R.V. Assessment of the Need for New Passenger Railcars for the Railways of Uzbekistan and Key Directions for Their Improvement. *Bulletin of TashIIT*. 2009;2:88-91. EDN CFLXCK. (In Russ.).
2. Rahimov R.V. The First Uzbek Long-Distance Passenger Railcar. *Heavy Engineering*. 2010;6:34-35. EDN MSNWLN. (In Russ.).
3. Shinkaruk A.S. Technical Preparation for Scheduled Preventive Maintenance of Double-Decker Rolling Stock. *World of Transport and Transportation*. 2023;21(4):53-61. (In Russ.).
4. Kammer R. Double-Decker Passenger Railcars of the German Railways. *World Railways*. 2008;12:34-39. (In Russ.).
5. Kallee S.W., Davenport J. Trends in Design and Fabrication of Rolling Stock. *European Railway Review*. 2007;1:75-79.
6. Lovska A., Gerlici J., Dižo J. Research of the possibility of using beams with corrugated walls in a passenger rail car frame. *Scientific Reports*. 2025;15:26833. DOI: 10.1038/s41598-025-12783-0.
7. Lovska A., Stanovska I., Nerubatskyi V., Hordiienko D., Zinchenko O., Karpenko N., Semenenko Y. Determining features of the stressed state of a passenger car frame with an energy-absorbing material in the girder beam. *Eastern-European Journal of Enterprise Technologies*. 2022;5(7(119)):44-53. DOI: 10.15587/1729-4061.2022.265043. EDN JIMGDC.
8. Zairova D., Kadirov M., Khojiev N., Khikmatov F., Shokuchkorov K. Running quality assessment of a passenger car produced in the Republic of Uzbekistan. *E3S Web of Conferences*. 2021;264:05058. DOI: 10.1051/e3sconf/202126405058. EDN VMEOJ.
9. Martynov I., Kalabuxin Y., Trufanova A., Martynov S. Analysis of passenger cars failures. *Municipal Economy of Cities*. 2024;6(187):289-294. DOI: 10.33042/2522-1809-2024-6-187-289-294. EDN BZSIMO.
10. Kirkpatrick S.W., MacNeill R.A. Development of a computer model for prediction of collision response of a railroad passenger car. *ASME/IEEE Joint Railroad Conference*. 2002:9-16. DOI: 10.1109/RRCON.2002.1000085.
11. Lan Q., Song F. Fatigue simulation of railway car bogie frame based on multi-body dynamics and finite element analysis. *Journal of Physics: Conference Series*. 2021;1885:042057. DOI: 10.1088/1742-6596/1885/4/042057. EDN YXUXBS.
12. Xie N., Lu Y.-H., Feng Z., Chen T.-L. Fatigue strength research on aluminum alloy car body for railway vehicle based on finite element analysis method. *Proceedings of the International Conference on Material Science and Applications*. 2015:885-891. DOI: 10.2991/icmsa-15.2015.164.
13. Sun W., Zhou J., Gong D., You T. Analysis of modal frequency optimization of railway vehicle car body. *Advances in Mechanical Engineering*. 2016;8(4):1-12. DOI: 10.1177/1687814016643640.
14. Jin X., Guo F. Fatigue research of metro car body based on operational loads. *Railway Sciences*. 2024;3(5):558-574. DOI: 10.1108/RS-06-2024-0023. EDN BLZJIS.
15. Baykasoglu C., Sunbuloglu E., Bozdog S.E., Aruk F., Toprak T., Mungan A. Numerical static and dynamic stress analysis on railway passenger and freight car models. *International Iron & Steel Symposium*. 2012. Karabük, Türkiye:579-586.
16. Rahimov R.V. A new compartment-type passenger railcar for the railways of Uzbekistan. *Proceedings of PGUPS*. 2010;2:286-295. (In Russ.).

## ЛИТЕРАТУРА

1. Бороненко Ю.П., Рахимов Р.В. Оценка потребности в новых пассажирских вагонах для железных дорог Узбекистана и основные направления их совершенствования // Вестник ТашИИТ. 2009. № 2. С. 88–91. EDN CFLXCK.
2. Рахимов Р.В. Первый узбекский пассажирский вагон дальнего следования // Тяжелое машиностроение. 2010. № 6. С. 34–35. EDN MSNWLN.
3. Shinkaruk A.S. Technical Preparation for Scheduled Preventive Maintenance of Double-Decker Rolling Stock // World of Transport and Transportation. 2023. Vol. 21. Iss. 4. P. 53–61. DOI: 10.30932/1992-3252-2023-21-4-6. EDN ZNNIMR.
4. Каммер Р. Двухэтажные пассажирские вагоны железных дорог Германии // Железные дороги мира. 2008. № 12. С. 34–39.
5. Kallee S.W., Davenport J. Trends in design and fabrication of rolling stock // European Railway Review. 2007. Vol. 1. P. 75–79.
6. Lovska A., Gerlici J., Dižo J. Research of the possibility of using beams with corrugated walls in a passenger rail car frame // Scientific Reports. 2025. Vol. 15. Art. 26833. P. 1–15. DOI: 10.1038/s41598-025-12783-0.
7. Lovska A., Stanovska I., Nerubatskyi V., Hordiienko D., Zinchenko O., Karpenko N., Semenenko Y. Determining features of the stressed state of a passenger car frame with an energy-absorbing material in the girder beam // Eastern-European Journal of Enterprise Technologies. 2022. Vol. 5. Iss. 7 (119). P. 44–53. DOI: 10.15587/1729-4061.2022.265043. EDN JIMGDC.
8. Zairova D., Kadirov M., Khojiev N., Khikmatov F., Shokuchkorov K. Running quality assessment of a passenger car produced in the Republic of Uzbekistan // E3S Web of Conferences. 2021. Vol. 264. Art. 05058. P. 1–6. DOI: 10.1051/e3sconf/202126405058. EDN VMEOJ.
9. Martynov I., Kalabuxin Y., Trufanova A., Martynov S. Analysis of passenger cars failures // Municipal Economy of Cities. 2024. Iss. 6 (187). P. 289–294. DOI: 10.33042/2522-1809-2024-6-187-289-294. EDN BZSIMO.
10. Kirkpatrick S.W., MacNeill R.A. Development of a computer model for prediction of collision response of a railroad passenger car // ASME/IEEE Joint Railroad Conference. 2002. P. 9–16. DOI: 10.1109/RRCON.2002.1000085.
11. Lan Q., Song F. Fatigue simulation of railway car bogie frame based on multi-body dynamics and finite element analysis // Journal of Physics: Conference Series. 2021. Vol. 1885. Art. 042057. P. 1–6. DOI: 10.1088/1742-6596/1885/4/042057. EDN YXUXBS.
12. Xie N., Lu Y.-H., Feng Z., Chen T.-L. Fatigue strength research on aluminum alloy car body for railway vehicle based on finite element analysis method // Proceedings of the International Conference on Material Science and Applications. 2015. P. 885–891. DOI: 10.2991/icmsa-15.2015.164.

13. Sun W., Zhou J., Gong D., You T. Analysis of modal frequency optimization of railway vehicle car body // *Advances in Mechanical Engineering*. 2016. Vol. 8. Iss. 4. P. 1–12. DOI: 10.1177/1687814016643640.

14. Jin X., Guo F. Fatigue research of metro car body based on operational loads // *Railway Sciences*. 2024. Vol. 3. Iss. 5. P. 558–574. DOI: 10.1108/RS-06-2024-0023. EDN BLZJIS.

15. Baykasoglu C., Sunbuloglu E., Bozdog S.E., Aruk F., Toprak T., Muga A. Numerical static and dynamic stress analysis on railway passenger and freight car models // *International Iron & Steel Symposium*. 2012. Karabük, Türkiye. P. 579–586.

16. Рахимов Р.В. Новый пассажирский вагон купейного типа для железных дорог Узбекистана // *Известия ПГУПС*. 2010. № 2. С. 286–295. EDN: MURSPH.

## Bionotes

**Rustam V. Rahimov** — Dr. Sci. (Tech.), Professor, Head of the Department, Department of “Wagons and wagon Facilities”, **Tashkent State Transport University (TSTU)**; 1 Temiryulchilar st., Mirabad District, Tashkent, Uzbekistan; RSCI ID: 914109, SPIN-code: 1459-5490; Scopus: 57203393911; ResearcherID: B-8975-2019; ORCID ID: 0000-0002-5652-2604; [https://www.researchgate.net/profile/Rustam\\_Rahimov](https://www.researchgate.net/profile/Rustam_Rahimov), <https://scholar.google.ru/citations?user=obcqC6IAAAA>; [rakhimovrv@yandex.ru](mailto:rakhimovrv@yandex.ru);

**Farida S. Galimova** — Cand. Sci. (Tech.), Associate Professor of the Department of “Wagons and wagon Facilities”, **Tashkent State Transport University (TSTU)**; 1 Temiryulchilar st., Mirabad District, Tashkent, Uzbekistan; Scopus: 57352424900, ORCID: 0000-0002-4919-2061; [farida.galimova.2020@inbox.ru](mailto:farida.galimova.2020@inbox.ru);

**Diyor Sh. Zafarov** — Cand. Sci. (Tech.), Associate Professor, Department of “Wagons and wagon Facilities”, **Tashkent State Transport University (TSTU)**; 1 Temiryulchilar st., Mirabad District, Tashkent, Uzbekistan; Scopus: 58567927900, ORCID: 0000-0003-0100-4815; [textmeback117@gmail.com](mailto:textmeback117@gmail.com).

## Об авторах

**Рустам Вячеславович Рахимов** — доктор технических наук, профессор, заведующий кафедрой «Вагоны и вагонное хозяйство»; **Ташкентский государственный транспортный университет (ТГТУ)**, Узбекистан, г. Ташкент, Мирабадский район, улица Темирийулчилар, д. 1; РИНЦ ID: 914109, SPIN-код: 1459-5490; Scopus: 57203393911; ResearcherID: B-8975-2019; ORCID ID: 0000-0002-5652-2604; [https://www.researchgate.net/profile/Rustam\\_Rahimov](https://www.researchgate.net/profile/Rustam_Rahimov), <https://scholar.google.ru/citations?user=obcqC6IAAAA>; [rakhimovrv@yandex.ru](mailto:rakhimovrv@yandex.ru);

**Фарида Салаватовна Галимова** — кандидат технических наук, доцент кафедры «Вагоны и вагонное хозяйство»; **Ташкентский государственный транспортный университет (ТГТУ)**, Узбекистан, г. Ташкент, Мирабадский район, ул. Темирийулчилар, д. 1; Scopus: 57352424900, ORCID: 0000-0002-4919-2061; [farida.galimova.2020@inbox.ru](mailto:farida.galimova.2020@inbox.ru);

**Дияр Шухратжон угли Зафаров** — кандидат технических наук, доцент кафедры «Вагоны и вагонное хозяйство»; **Ташкентский государственный транспортный университет (ТГТУ)**; Scopus: 58567927900, ORCID: 0000-0003-0100-4815; Узбекистан, г. Ташкент, Мирабадский район, улица Темирийулчилар, дом 1, [textmeback117@gmail.com](mailto:textmeback117@gmail.com).

Contribution of the authors: the authors contributed equally to this article.

The authors declare no conflicts of interests.

Заявленный вклад авторов: все авторы сделали эквивалентный вклад в подготовку публикации.

Авторы заявляют об отсутствии конфликта интересов.

Corresponding author: Rustam V. Rahimov, [rakhimovrv@yandex.ru](mailto:rakhimovrv@yandex.ru).

Автор, ответственный за переписку: Рустам Вячеславович Рахимов, [rakhimovrv@yandex.ru](mailto:rakhimovrv@yandex.ru).

The article was submitted 28.06.2025; approved after reviewing 29.07.2025; accepted for publication 29.08.2025.

Статья поступила в редакцию 28.06.2025; одобрена после рецензирования 29.07.2025; принята к публикации 29.08.2025.

Review article

UDC / УДК 378:656

doi: 10.46684/2025.3.04

EDN GXBKXY

## Major aspects of interaction between Russian and Chinese educational institutions for the benefit of sectoral economy

Maksim A. Garanin<sup>1✉</sup>, Zeng Qingjun<sup>2</sup>

<sup>1</sup> Volga State Transport University (VSTU); Samara, Russian Federation

<sup>2</sup> Liaoning Railway Vocational and Technical College, Jinzhou City, Liaoning Province, People's Republic of China

<sup>1</sup> garanin@samgups.ru<sup>✉</sup>; <https://orcid.org/0000-0002-9773-5294>

<sup>2</sup> ltyzqj@126.com

**ABSTRACT** The article discusses the main aspects of the interaction between transport universities of Russia and the People's Republic of China for improving the performance of the railway industry in terms of transportation of goods and passengers. The analysis takes account of the specific features of the transport and logistics sectors in the exchange of goods between the two countries. Cooperation in the field of transportation of goods and passengers is based on the market situation. However, approaches to training professionals for solving new challenges are not given sufficient attention. Given the reorientation of the main transport flows towards the East and the active loading of the traffic in international transport corridors, improving the performance of the transport systems in the two countries requires further development of transport hubs bringing together logistics and capacities of various transport modes. This will require training highly skilled personnel on the basis of common educational standards of both Russia and China. At the same time, students, as prospective specialists, should understand the specific features of geo-economic interaction, the nature of the development of cross-border logistics centres, and have an idea of the full operational cycle: from industrial to transport implementation in logistics of transportation. The solution lies in the development and implementation of joint educational programmes and curricula of industry-specific educational institutions in the two countries. Volga State Transport University and Liaoning Railway Vocational and Technical College implement joint educational partnership programmes within the framework of their cooperation agreement. In the future, it will be necessary to implement joint educational projects with elements of a multicultural approach for training both students and working professionals.

**KEYWORDS:** One Belt, One Road; railway transport; transport corridors; cross-border centre; infrastructure; trade turnover; professional education

**For citation:** Garanin M.A., Zeng Qingjun. Major aspects of interaction between Russian and Chinese educational institutions for the benefit of sectoral economy. *BRICS transport*. 2025;4(3):04. <https://doi.org/10.46684/2025.3.04>. EDN GXBKXY.

Обзорная статья

## Актуальные аспекты взаимодействия российских и китайских образовательных организаций в интересах отраслевой экономики

М.А. Гаранин<sup>1✉</sup>, Цзэн Цинцзюнь<sup>2</sup>

<sup>1</sup> Приволжский государственный университет путей сообщения (ПривГУПС); г. Самара, Россия

<sup>2</sup> Ляонинский железнодорожный институт; район Линхэ, город Цзиньчжоу, провинция Ляонин, Китайская Народная республика

<sup>1</sup> garanin@samgups.ru<sup>✉</sup>; <https://orcid.org/0000-0002-9773-5294>

<sup>2</sup> ltyzqj@126.com

© Maksim A. Garanin, Zeng Qingjun, 2025

© Translation into English "BRICS Transport", 2025

**АННОТАЦИЯ** Рассматриваются основные аспекты взаимодействия транспортных вузов России и Китайской Народной Республики для повышения эффективности железнодорожной отрасли в части грузовых и пассажирских перевозок. Анализ выполнен с учетом транспортно-логистических особенностей в товарообмене двух стран. Взаимодействие в сфере грузовых и пассажирских перевозок ориентировано на рыночную конъюнктуру. Однако при этом не уделяется достаточного внимания тому, как готовить специалистов для решения новых задач. В условиях переориентации основных транспортных потоков на Восток и активной загрузки международных транспортных коридоров для повышения эффективности работы транспортного комплекса двух стран требуется дальнейшее развитие транспортных хабов, связывающих логистику и потенциал различных видов транспорта. Для этого необходимо готовить квалифицированные кадры по общим образовательным стандартам двух стран – России и КНР. При этом обучающиеся – будущие специалисты – должны понимать специфику геоэкономического взаимодействия, характер развития трансграничных логистических центров, а также иметь представление о полном цикле производства от промышленного до транспортного воплощения в логистике перевозок. Решение задачи кроется в формировании и реализации совместных образовательных программ, учебных планов отраслевых учебных заведений двух стран. Приволжский государственный университет путей сообщения и Ляонинский железнодорожный институт в рамках соглашения о сотрудничестве реализуют совместные партнерские образовательные программы. В перспективе необходима реализация совместных образовательных проектов с элементами мультикультурного подхода для подготовки не только студентов, но и работающих специалистов.

**КЛЮЧЕВЫЕ СЛОВА:** «Один пояс; один путь»; железнодорожный транспорт; транспортные коридоры; трансграничный центр; инфраструктура; товарооборот; профессиональное образование

**Для цитирования:** Garanin M.A., Zeng Qingjun. Актуальные аспекты взаимодействия российских и китайских образовательных организаций в интересах отраслевой экономики // Транспорт БРИКС. 2025. Т. 4. Вып. 3. Ст. 04. <https://doi.org/10.46684/2025.3.04>. EDN GXBKXY.

## INTRODUCTION

The current global geopolitical and economic situation makes business entities switch to new target markets and search for new partners. The economy of the People's Republic of China has been an alternative for Russian businesses and state-owned enterprises for several years. The potential of this direction became evident ten years back, when the growing Chinese economy was in dire need for energy resources and raw materials for industrial enterprises. China was able to offer export of manufactured goods, microelectronics, and means of production. With the introduction of unilateral discriminatory measures against Russia by Western countries, the range of Chinese products became significantly broader. In just a couple of years, products of the Chinese automotive industry have topped statistics for sales, and Chinese-made machinery and equipment are being installed at newly launched and reconstructed facilities in Russia. To ensure efficient logistics for merchandise trade between the two countries, which is growing year after year, several federal programmes and joint projects in the transport sector have been developed. Given the length of land borders between Russia and China, overland transport modes have good development prospects and railway transport is most effective in terms of the route length and large carrying capacity.

No sector of economy can function without skilled professionals, and institutions of professional education are designed to train them. The purpose of this

article is to review the transport sector from the perspective of interaction between Russian and Chinese educational institutions.

## MAIN AREAS AND PROSPECTS OF DEVELOPMENT OF RELATIONS IN THE RAILWAY SECTOR

The railway transportation sphere develops through the implementation of a number of comprehensive projects.

As early as 2013, China put forward a strategic initiative known as “One Belt, One Road” [1]. The main goal of the project is to strengthen economic ties and cooperation between China and Eurasian countries. The project involves the joint development of the geo-economic infrastructure of Russia and China. The strategy is based on the development of railway transport and related enterprises: construction of new railway lines, development of adjacent areas and cities, retrofitting of existing railways lines, etc. Much attention is also given to transport hubs linking various modes of transport into a single network structure for transporting goods and passengers. All these activities are aimed at making the two economies less dependent on changes in the geopolitical and economic situation in the world.

The initiative involves the development of several transport corridors, some of which will almost entirely run across Russia and others will partially involve oth-



Fig. 1. Map of the major trans-Eurasian corridors

er countries of the Eurasian Economic Union (EAEU) (Fig. 1) [2].

Mutual investments of Russia and China are an important aspect for the development of relations in the transport sector, as they both provide a significant inflow of resources to current projects and strengthen economic and political ties. Optimization of resource consumption is an equally important advantage of these initiatives.

In order to develop joint educational programmes, Russian and Chinese universities have to understand the specific features and challenges of operation of the entire railway industry comprising several components.

These, in particular, include the following:

- Construction of tracks and related infrastructure;
- Manufacturing of rolling stock;
- Transportation of goods;
- Transportation of passengers.

Each of the components is discussed in more detail below.

## CONSTRUCTION AND DEVELOPMENT OF INFRASTRUCTURE

The implementation of global projects involves the development of the railway network and related infrastructure.

In 2022, Nizhneleninskoye–Tongjiang bridge across the Amur River was opened in the Jewish Autonomous Region, which is the first cross-border railway bridge

to China. It is a single-track, dual-gauge railway bridge capable of accommodating both Russian and Chinese trains. The project was implemented by the Russian Direct Investment Fund through the Russia–China Fund (CIC) (with a 56.25% interest in the project company), RZhD JSC (25%) and VEB.DV (18.75%). The project value is about RUB 10 billion [3]. The project is the first railway border crossing between the two countries.

However, the bridge crossing over the Amur is far away from mineral deposits in Central Siberia, therefore a more conveniently located facility is needed. This could be the Zabaikalsk–Manchuria border crossing, and its infrastructure is being actively developed by both parties [4, 5].

In addition to the construction of new routes, is the existing ones are supposed to be expanded: both those directly involved in cross-border cooperation and indirectly involving it, but, in particular, those intended for domestic freight flows.

A potential project here is the construction of two new railway lines along the following routes:

- The North Siberian Railway will have two branches: from Nizhnevartovsk to Bely Yar in Tomsk Region and from Tashtagol in Kemerovo Region to Urumqi in China;
- Through the Republic of Tuva to the south across the Russian border to Mongolia, where the line will also split into two. One track will run to Erlian in China and the other will go via Mongolian cities to Urumqi [6].

The implementation of the new project will help strengthen ties both with China and with Mongolia.

Due to a special nature of the development of cross-border logistics centres, there is a need for training both engineers and blue-collar workers, and training programmes in both Russian and Chinese universities should have common modules and be based on agreed approaches to the subject matters. Volga State Transport University and its partners are implementing joint training programmes both for sharing experience and training professionals for work in related projects.

The development of transport and logistics infrastructures is necessary for expanding the network capacity for accommodating the growing freight and passenger flows.

## ROLLING STOCK PRODUCTION

Rolling stock is the main means of transportation of goods and passengers. The successful performance of railways depends on is the availability of a well-developed mechanical engineering industry. Unfortunately, the situation with the manufacturing of wagons and locomotives in Russia is bad.

“In 2023–2025, the supply of new freight wagons for the Russian Railways network may drop 19.2% compared to 2020–2022 to 137.6 thousand items. Further, in 2026–2028, analysts expect the supply to reach 154.3 thousand items — a 12.1% increase compared to 2023–2025, but this will still be 9.4% below the level recorded in 2020–2022 (170.4 thousand)” [7].

The withdrawal of European partners of Russian enterprises [8] leads to need to search for new ones outside Europe. In this sector, Chinese companies are quite a promising alternative.

But localization of production is quite a complex process as such, and in the current situation, Russian companies also need to revise their product lines and

either abandon already running projects or develop new ones. In any case, the achievement of technological sovereignty for railway traction vehicles requires large amounts of financial, production, intellectual and human resources.

In this regard, there is a clear need for the development and implementation of student training programmes involving foreign teachers and workers of Chinese enterprises. Internships at both Russian and foreign enterprises will be a useful aid. However, this will require developing a comprehensive project that will need to involve many industry representatives.

Now that we have discussed the issues related to rolling stock, let us consider those on managing transportation of goods.

## TRANSPORTATION OF GOODS

In percentage terms, transportation of goods dominates the overall trade between Russia and China. This is due to the economic characteristics of the two. With its enormous need for energy products, China is interested in importing them, and with its huge reserves of carbohydrates Russia can supply them in large quantities. Therefore, the countries have entered into long-term contracts for the supply of coal, oil and gas.

Apart from energy resources, the Chinese economy is in dire need for wood for construction and wood-based industries.

In addition to expanding product types available for trade, their sales volumes also grow. *Table 1* shows trade statistics in 2015–2023 (in USD million).

In the period in question, merchandise trade between Russia and China shows a steady upward trend, which is beneficial for both economies, allowing for diversification of the target markets and improving their resilience to downturns.

Table 1

Dynamics of merchandise trade between Russia and China in 2015–2023, USD million

Year	Turnover	Exports from Russia to China	Imports to Russia from China	Trade balance	Growth rates, %	
					chain indices	base indices
2015	63,555	34,950	28,605	6,345	100.00	100.00
2016	66,108	38,087	28,021	10,066	104.02	104.02
2017	86,964	48,042	38,922	9,120	131.55	136.83
2018	108,284	52,218	56,066	–3,848	124.52	170.38
2019	110,919	54,127	56,792	–2,665	102.43	174.52
2020	103,969	54,908	49,061	5,847	93.73	163.59
2021	140,703	68,028	72,675	–4,647	135.33	221.39
2022	190,270	114,150	76,120	38,030	135.23	299.38
2023	240,100	129,130	110,970	18,160	126.19	377.78

One of the challenges in logistics of railway services between the two countries is an unbalanced structure of merchandise trade. Specifically, while the base of exports from Russia is resource materials and energy products which are transported in tank and other special-purpose wagons, goods imported from China are mainly machines, equipment and other finished products for industrial and consumer applications which are transported in containers. This creates a problem of empty runs in the opposite direction. Accordingly, it is necessary to balance the structure of merchandise trade by product type or design multi-purpose wagons for a wider range of goods.

All of the above indicates the need for training railway professionals with a mindset conducive to the integrated development of both transport and logistics facilities as well as their active interaction with industrial enterprises for the implementation of joint investment projects. In addition, academic exchange programmes for students and teachers will help add more relevant content to educational programmes and in the long run will enable young transport specialists to effectively contribute to programmes for integrated development of industrial territories both in Russia and in China. Close contacts between students from the two countries will enable each student to learn about culture and mentality of their foreign counterparts, acquire interpersonal skills in a culturally informed way, and take a closer look at engineering cultures in both countries.

Although cargo services account for the major share of the railway traffic between Russia and China, passenger flows between the two also tend to increase.

## TRANSPORTATION OF PASSENGERS

There are several factors contributing to the rapid growth of passenger services between the countries. Firstly, it is the low base effect caused by the pandemic restrictions both in Russia and China. Secondly, a sharp increase in exchange of goods necessitates a higher frequency of international trips and involves more and more people in business processes of international

cooperation. Thirdly, the geopolitical situation contributes to both economic and socio-cultural integration of the two countries, switching business and tourism links from Western Europe to Asian countries and China in particular.

Although railway services cannot fully compete with air passenger transport due to large distances between Russian and Chinese business and tourist centres, they play a notable role in international passenger logistics.

To resolve the present challenges in international passenger logistics, it is necessary to develop all of its components, improve the available infrastructure, raise the quality level of wagons, and train multi-culturally-oriented professionals. This is relevant both for railway workers and for personnel of related transport infrastructure companies and organisations.

## CONCLUSION

The prospects of Russia–China relations in the field of transport require building effective interaction between transport universities in Russia and China. Since goods are mainly transported by rail, it is railway transport universities that can make a major contribution to the development of these processes.

There is a pressing need for training railway sector professionals, as staffing needs are high both in railway companies and in related sectors.

Any industry develops better when it uses resources of many institutional entities, especially those from various leading global economies.

The geopolitical and economic conditions prevailing in the modern world are indicative of a need for closer convergence of Russia and China. Joint efforts of the two will help create a synergy in the development of both the transport sector and related enterprises, organisations and entire territories.

In this connection, it is necessary to develop and implement academic exchange programmes both for students and teachers and railway workers in the two countries.

## REFERENCES

1. Belt and Road Initiative. The World Bank. URL: <https://www.worldbank.org/en/topic/regional-integration/brief/belt-and-road-initiative>.
2. Vinokurov E.Yu., Lobyrev V.G., Tikhomirov A.A., Tsukarev T.V. *Transport corridors of the Silk Road: potential for growth of cargo flows through the EAEU*. St. Petersburg: EDB Center for Integration Studies, 2018. 74 p. (In Russ.).
3. Russia opens first cross-border railway bridge to China. *RIA Novosti Information Agency*. 04/27/2022. URL: <https://company.rzd.ru/ru/9401/page/78314?id=22297>. (In Russ.).
4. Zabaikalsk – Manchuria will become the main border crossing between Russia and China. *Gudok Publishing House*. 29.08.2023. URL: <https://gudok.ru/content/infrastructure/1644703/>. (In Russ.).

5. Trutnev supported the idea of building a new border crossing to China. *RIA Novosti Information Agency*. 07.06.2022. URL: <https://company.rzd.ru/ru/9401/page/78314?id=203061>. (In Russ.).

6. Russia plans to extend two more railways to China. The scale of the construction is comparable to the BAM. *Publishing House "Rossiyskaya Gazeta"*. 24.10.2023. URL: <https://rg.ru/2023/10/24/kashemir-vashemu-domu.html>. (In Russ.).

7. The rolling stock fleet is losing traction. Rollingstock experts predict a decline in the production of freight cars. *RBC*. 14.04.2023. URL: <https://www.rbc.ru/newspaper/2023/04/14/643804a49a7947a62d573cdd>. (In Russ.).

8. Siemens is leaving Russia, but is not ready to leave China under the same conditions "ROLLINGSTOCK", 18.05.2022. URL: <https://rollingstockworld.ru/ekonomika/siemens-uhodit-iz-rossii-no-ne-gotova-v-takih-zhe-usloviyah-pokidat-kitaj/>. Accessed 02/15/2024. (In Russ.).

## ЛИТЕРАТУРА

1. Belt and Road Initiative. The World Bank. URL: <https://www.worldbank.org/en/topic/regional-integration/brief/belt-and-road-initiative>.

2. Винокуров Е.Ю., Лобырев В.Г., Тихомиров А.А., Цукарев Т.В. Транспортные коридоры Шелкового пути: потенциал роста грузопотоков через ЕАЭС. СПб.: ЦИИ ЕАБР, 2018. 74 с.

3. В России открыли первый трансграничный железнодорожный мост в Китай // ИА «РИА Новости». 27.04.2022. URL: <https://company.rzd.ru/ru/9401/page/78314?id=202297>.

4. Забайкальск – Маньчжурия станет основным погранпереходом между Россией и Китаем // ИД «Гудок». 29.08.2023. URL: <https://gudok.ru/content/infrastructure/1644703/>.

5. Трутнев поддержал идею строительства нового погранперехода в Китай // ИА «РИА Новости». 07.06.2022. URL: <https://company.rzd.ru/ru/9401/page/78314?id=203061>.

6. Россия планирует протянуть в Китай еще две железные дороги. Масштабы стройки сопоставимы с БАМом // ИД «РГ». 24.10.2023. URL: <https://rg.ru/2023/10/24/kashemir-vashemu-domu.html>.

7. Вагонный парк теряет тягу. Эксперты Rollingstock прогнозируют падение производства грузовых вагонов. РБК. 14.04.2023. URL: <https://www.rbc.ru/newspaper/2023/04/14/643804a49a7947a62d573cdd>.

8. Siemens уходит из России, но не готова в таких же условиях покинуть Китай // «ROLLINGSTOCK». 18.05.2022. URL: <https://rollingstockworld.ru/ekonomika/siemens-uhodit-iz-rossii-no-ne-gotova-v-takih-zhe-usloviyah-pokidat-kitaj/>. Доступ 15.02.2024.

## Bionotes

**Maksim A. Garanin** — Cand. Sci. (Tech.), Dr. Sci. (Econom.), Associate Professor, rector; Volga State Transport University (VSTU); Doctor of Economics, Associate Professor, Rector; **Volga State Transport University (VSTU)**; 2 v, Svobody st., Samara, 443066, Russian Federation; SPIN-code: 1919-4849, RSCI ID: 295115, Scopus: 57194346582, Researcher ID: ABB-6867-2020, ORCID: 0000-0002-9773-5294; garanin@samgups.ru;

**Zeng Qingjun** — Professor, Master's degree; **Liaoning Railway Vocational and Technical College Party Secretary**; number 129, Senpoli, Linghe District, Jinzhou City, Liaoning Province, 121000, People's Republic of China; ltyzqj@126.com

## Об авторах

**Максим Алексеевич Гаранин** — кандидат технических наук, доктор экономических наук, доцент, ректор; **Приволжский государственный университет путей сообщения (ПривГУПС)**; 443066, г. Самара, ул. Свободы, д. 2 в; SPIN-код: 1919-4849, РИНЦ ID: 295115, Scopus: 57194346582, Researcher ID: ABB-6867-2020, ORCID: 0000-0002-9773-5294; garanin@samgups.ru;

**Цзэн Цинцзюнь** — профессор, магистр, секретарь парткома; **Ляонинский железнодорожный институт**; 121000, номер 129, Сунполи, район Линхэ, город Цзиньчжоу, провинция Ляонин; ltyzqj@126.com.

Contribution of the authors: the authors contributed equally to this article.

The authors declare no conflicts of interests.

Заявленный вклад авторов: все авторы сделали эквивалентный вклад в подготовку публикации.

Авторы заявляют об отсутствии конфликта интересов.

Corresponding author: Maksim A. Garanin, garanin@samgups.ru.

Автор, ответственный за переписку: Максим Алексеевич Гаранин, garanin@samgups.ru.

The article was submitted 22.06.2025; approved after reviewing 22.07.2025; accepted for publication 28.08.2025.

Статья поступила в редакцию 22.06.2025; одобрена после рецензирования 22.07.2025; принята к публикации 28.08.2025.

Review article

UDC 338.24:656.6

doi: 10.46684/2025.3.05

EDN UCFGKN

## Shipbuilding industry of Russia: State and problems of strategic development<sup>1</sup>

Nataliya E. Tereshkina<sup>1✉</sup>, Ol'ga A. Khalturina<sup>2</sup>

<sup>1</sup> Siberian Transport University (STU); Novosibirsk, Russian Federation

<sup>2</sup> Novosibirsk State University of Economics and Management (NSUEM); Novosibirsk, Russian Federation

<sup>1</sup> phd\_76@mail.ru✉; <https://orcid.org/0000-0002-1303-8871>

<sup>2</sup> olga\_andre@mail.ru; <https://orcid.org/0000-0001-6264-3042>

**ABSTRACT** Shipbuilding is a major labour-, capital- and technology-intensive industry for Russia providing products for water transport, offshore and onshore construction, state defence procurement programme, mining, fishing, etc. A current crucial task to identify factors preventing the long-term development of shipbuilding in Russia and analyse government support measures aimed at mitigating them. The paper examines the state of the shipbuilding industry in Russia and related strategic public management issues.

The materials used include regulatory legal acts of the Russian Federation, official statistics, and works by Russian scholars. The study uses scientific methods such as formalization, visualization, comparison, synthesis, induction, and generalization.

The paper considers both global and domestic trends in shipbuilding and its main participants. It identifies and validates both endogenous (ineffective management; obsolescence and physical depreciation of equipment and fleet; instability of the industry as a socio-economic system; inadequacy of the number and capacities of existing enterprises to the growing demand; use of outdated shipbuilding technologies; increase in the key interest rate, and inflation processes) and exogenous (sanctions policies of unfriendly countries; deglobalization processes, the increasing numbers of international intermediaries, changes in international logistics and supply chains) factors that hamper the development of shipbuilding in the country. The authors analyse the state strategic instruments for the regulation of the industry in the long and medium term, including their drawbacks, and assess the level of financing of the subject sector from the national budget.

The analysis has led the authors to the conclusion that endogenous factors prevail over exogenous ones, hindering further strategic development of the subject industry. In practical terms, the study puts forward a number of activities intended to mitigate the negative internal factors identified. These specifically include amending the Law "On Strategic Planning in the Russian Federation"; using more rigorous measures to monitor and control spending of special-purpose funds and ensure efficient achievement of strategic goals and objectives; and increasing regulation for providing full responsibility of top executives of state corporations for failures and non-achievement of long-term goals and objectives defined earlier.

**KEYWORDS:** shipbuilding; strategic public management; development; endogenous and exogenous factors

**For citation:** Tereshkina N.E., Khalturina O.A. Shipbuilding industry of Russia: State and problems of strategic development. *BRICS transport*. 2025;4(3):05. <https://doi.org/10.46684/2025.3.05>. EDN UCFGKN.

Обзорная статья

## Судостроительная отрасль России: состояние и проблемы стратегического развития<sup>1</sup>

<sup>1</sup> Published in Russian: Tereshkina N.E., Khalturina O.A. Shipbuilding industry of Russia: state and problems of strategic development. *Transport in the Russian Federation. Journal of Science, Practice, Economics*. 2025;2(117):10-15. EDN TUUNIP.

На русском языке опубликовано: Терешкина Н.Е., Халтурина О.А. Судостроение России: состояние и проблемы стратегического развития // Транспорт Российской Федерации. Журнал о науке, практике, экономике. 2025. № 2(117). С. 10–15. EDN TUUNIP.

© Nataliya E. Tereshkina, Ol'ga A. Khalturina, 2025

© Translation into English "BRICS Transport", 2025

Н.Е. Терешкина<sup>1✉</sup>, О.А. Халтурина<sup>2</sup>

<sup>1</sup> Сибирский государственный университет путей сообщения (СГУПС); Новосибирск, Россия

<sup>2</sup> Новосибирский государственный университет экономики и управления (НГУЭУ); Новосибирск, Россия

<sup>1</sup> phd\_76@mail.ru✉; <https://orcid.org/0000-0002-1303-8871>

<sup>2</sup> olga\_andre@mail.ru; <https://orcid.org/0000-0001-6264-3042>

**АННОТАЦИЯ** Судостроительная промышленность — важнейшая для России трудоемкая, капиталоемкая и высокотехнологичная отрасль, которая производит продукцию для водного транспорта, морского и прибрежного строительства, гособоронзаказа, добычи полезных ископаемых, рыболовства и др. При этом сегодня актуальной задачей является выявление факторов, препятствующих долгосрочному развитию отечественного судостроения и анализ мер государственной поддержки, направленных на снижение их воздействия. Статья посвящена исследованию состояния судостроительной отрасли в России и стратегическому государственному управлению ею.

Материалами послужили нормативно-правовые акты РФ, официальные статистические данные, а также работы отечественных авторов. При проведении исследования использовались такие научные методы, как формализация, визуализация, сравнение, синтез, индукция и обобщение.

В работе рассмотрены мировые и отечественные тенденции судостроения и основные его участники; выявлены и обоснованы эндогенные (неэффективный менеджмент; моральное старение и физический износ оборудования и флота; неустойчивость функционирования отрасли как социально-экономической системы; недостаточное количество имеющихся предприятий и их мощностей для удовлетворения растущего спроса; применение устаревших технологий строительства судов; увеличение ключевой ставки и инфляционные процессы) и экзогенные (санкционная политика недружественных стран; процессы деглобализации, рост числа международных посредников, изменение международной логистики и цепочек поставок) факторы, препятствующие развитию судостроения в стране; проанализированы государственные стратегические документы, направленные на регулирование отрасли в долго- и среднесрочном периодах, и их недостатки; проведена оценка уровня финансирования за счет государственного бюджета исследуемой сферы.

В результате проведенного анализа авторы пришли к выводу, что эндогенные факторы доминируют над экзогенными и препятствуют дальнейшему стратегическому развитию исследуемой отрасли. С практической точки зрения предложен ряд мероприятий, направленных на снижение негативного влияния выявленных внутренних факторов, а именно: внесение изменений в закон «О стратегическом планировании в РФ»; ужесточение процедур мониторинга и контроля целевого расходования средств и четкого достижения поставленных стратегических целей и задач; усиление регулирования вопроса полной ответственности высшего менеджмента государственных корпораций за провалы и недостигнутые поставленные ранее долгосрочные цели и задачи.

**КЛЮЧЕВЫЕ СЛОВА:** судостроение; стратегическое государственное управление; развитие; эндогенные и экзогенные факторы

**Для цитирования:** Терешкина Н.Е., Халтурина О.А. Судостроительная отрасль России: состояние и проблемы стратегического развития // Транспорт БРИКС. 2025. Т. 4. Вып. 3. Ст. 05. <https://doi.org/10.46684/2025.3.05>. EDN UCFGKN.

## INTRODUCTION

Shipbuilding is a modern integrated industry which manufactures and sells shipbuilding products and supplies mechanical equipment for water transport, offshore construction projects, state defence procurement programme, and other sectors. It plays an important role and is essential for employment promotion, increasing export trade, provision of coastal areas, and defence security. It is also a labour- and capital-intensive industry crucial for the development of mining and manufacturing industries, such as resource survey and mining, electromechanical, steel, chemical, ship repair and fishing industries, software, telecommunications, and navigation.

Besides being the world's largest territory, Russia has 38.8 thousand km of maritime borders, 44 thou-

sand km of the overall coastal line of its borders, and 101.5 thousand km of inland waterways, 78% of them mainly used as a channel for delivery of goods and passengers, with 53.4 thousand km used for provision of residents of the Far North.

The materials used for this study include regulatory legal acts of the Russian Federation, official statistics, and works by Russian scholars. The study uses scientific methods such as formalization, visualization, comparison, synthesis, induction, and generalization.

## FINDINGS

The last decade has seen a decline in the world's shipbuilding industry compared, for example, with 2010–2012, and consequently, increasing operational

Table 1

**Total number and growth rates of output of ships and vessels with a displacement of over 50 thousand tonnes built in Russia [2]**

Indicator	Period										
	2014	2015	2016	2017	2018	2019	2020	2021	2022	2023	2024
Quantity, ships	141	134	89	100	122	101	108	94	82	112	125
Growth rates, %	100.0	95.04	64.18	116.28	122.0	82.79	106.93	87.04	87.23	136.59	111.61

lives of existing ships while toughening environmental requirements to them<sup>2</sup>.

World prices in the shipbuilding sector have been consistently growing. In 2023, the annual price index for new ships reached 178, showing a 10.2% increase at the end of the year. At the same time, the annual price index for used ships was 149 points, indicating a slight (2%) increase over the year.

The number of orders for new ships increased from 100.5 million DWT in 2022 to 116.5 million DWT in 2023. The number of ships built in 2023 also increased to 81.1 million DWT (1,301 ships) as compared to 79.1 million DWT (1,294 ships) in 2022. The global building programme increased from 243 million DWT at the end of 2022 to 277.3 million DWT at the end of 2023, which accounts for 12.5% of the active fleet.

2023 also saw a great number of transactions in the used ship market: 3,805 ships (205 million DWT). This is slightly fewer than in 2022, when 4,301 ships (216 million DWT) were sold<sup>3</sup>.

The major players in the global competition in the shipbuilding industry are China, Japan and South Korea, while Europe and developing shipbuilding economies (such as Vietnam and the Philippines) have smaller market shares. China demonstrates absolute control over the market of bulk carriers, oil tankers and car carriers, while South Korea plays the most prominent role in the LNG carrier segment.

Overall, China has been the leader in global shipbuilding for 14 years in a row. In 2023, China's completed shipbuilding output was 42.32 million DWT (an 11.8% growth compared to the same period of the previous year) and the number of new orders received was 71.2 million DWT (plus 56.4%).

As of the late December 2023, the number of orders on hand was 139.39 million DWT, which is 32% more than a year earlier. In particular, in 2023, China completed the construction of 34.53 million DWT of ships for export (plus 12.6%). Orders for export

ships received amounted to 66.51 million DWT (plus 64.1%), and export orders for ships were 130.15 million DWT (plus 36.7%). Export vessels accounted for 81.6%, 93.4%, and 93.4% of the country's completed shipbuilding orders, new orders, and orders on hand, respectively<sup>4</sup>.

Territorially, the Northwestern Federal District accounts for the largest number of shipbuilding enterprises and output in Russia: 45% and 61.1% of Russia's total number and output, respectively.

The following state associations control 90% of the entire industry:

- Civil shipbuilding: United Shipbuilding Corporation JSC (hereinafter "OSC JSC"), Ak Bars Shipbuilding Corporation JSC, Modern Shipbuilding Technologies JSC, Centre for Shipbuilding and Ship Repair Technology JSC, and Marine Instrument Engineering Corporation JSC;
- Military shipbuilding: Rostec State Corporation (Remvooruzhenie JSC), Almaz-Antey Concern JSC, Tactical Missile Weapons Corporation JSC.

According to the Ministry of Industry and Trade, in 2024, the industry comprised 440 organisations, including 332 industrial enterprises, 88 design bureaus and research and development organisations, and 20 other service-related companies [1].

Table 1 shows changes in the amount and growth rates of output in civil and military shipbuilding over the last 11 years.

Despite the increasing total number of ships and vessels with a displacement of over 50 thousand tonnes commissioned in 2024 by 43 ships or 1.5 times to reach 125 against 82 in 2022, the majority of ships built were small-capacity ones. At the same time, in the recent years in Russia, commissioning of large-capacity (over 100 thousand tonnes) vessels demonstrated a particularly dramatic decline [3].

It is very difficult to identify sustainable long-term targets for building ships in Russia. For example, in

<sup>2</sup> 2024 Review of maritime transport. Chapter II. World shipping fleet and services / unctad. URL: [https://unctad.org/system/files/official-document/rmt2024ch2\\_en.pdf](https://unctad.org/system/files/official-document/rmt2024ch2_en.pdf)

<sup>3</sup> Shipping and Shipbuilding Markets, 2024 / BRS Group. URL: [https://it4resources.interactiv-doc.fr/catalogues/annual\\_review\\_2024\\_668/galleries/1711537990annual\\_rev.pdf](https://it4resources.interactiv-doc.fr/catalogues/annual_review_2024_668/galleries/1711537990annual_rev.pdf)

<sup>4</sup> 2023 年船舶工业经济运行报告 // URL: <http://lwzb.stats.gov.cn/pub/lwzb/bztt/202405/W020240527578179701223.pdf>

2023, the Ministry of Industry and Trade adjusted the shipbuilding plan to 985 ships (which will include 93 medium-capacity and 60 large-capacity ones) by 2035 against the previous target of 1,101 ships, clarifying that the number of ships to be built under government-sponsored programs will not change.

Following a meeting between the President of Russia and the Government on March 14, 2024, instructions were issued to re-update the Long-term Shipbuilding Plan until 2035 and the Strategy for the Development of the Shipbuilding Industry for the Period until 2035 approved on October 28, 2019. As of the early 2025, no changes to the above mentioned Plan and Strategy were made.

The Chairman of the Government reported that the Long-term Shipbuilding Plan until 2037 includes building 1,700 civilian ships. Besides, in the early 2025, the Integrated Plan for the Achievement of National Development Goals of the Russian Federation until 2030 and in the Longer Run until 2036 was posted on the Government's website. According to the Plan, 105 ships are to be built in 2025 and the number will gradually increase to 638 ships by 2030<sup>5</sup>.

It should be noted that strategically, frequent adjustments are undesirable, as they make the operation of all industry stakeholders less stable.

The key challenges faced by the industry include a number of endogenous and exogenous factors hampering the development of shipbuilding in Russia. The authors believe that endogenous factors prevail over exogenous ones.

Accordingly, the consequences of internal mistakes and blunders made in the industry after the collapse of the USSR should be corrected in an elaborate and careful manner. Exogenous factors can potentially give a boost for increasing the country's own diverse and unique production, forming key competencies in staff and increasing competitiveness of products in the future.

The following can be referred to negative endogenous factors in the shipbuilding industry:

- Ineffective management. The most outstanding example here is loss-making performance of OSK JSC, resulting in the appointment of a new CEO and new board of directors in August 2023 and placing 100% of its shares under management with VTB PJSC for five years. The latter is also a somewhat questionable solution, as the bank's representatives are geared to fast growth of business profitability, which is impossible in the current situation, not to

mention that they lack expertise in shipbuilding. There are a lot of cases in the economy when top managers failed to take account of all the specific aspects of unrelated diversification, leading to losses and abandonment of the business acquired.

- Obsolescence and physical depreciation of both equipment at enterprises and the fleet itself, and the need to modernize them promptly and thoroughly [4]. The industry features a high degree of deterioration of workshop premises, launch and recovery systems, and slipways at shipyards, as well as bottlenecks in production processes [5]. For example, an audit of OSK JSChas found that the company still uses the equipment produced in Germany in 1932. An illustration of the technical condition of Russian companies' fleet and its operation beyond all reason is a recent tragic incident (and not the first case) with casualties and significant regional environmental damage in the Kerch Strait, where the Volgoneft 212 fuel oil tanker (launched at the Volgograd Shipyard 56 years ago on December 15, 1969) was damaged and ran aground and the Volgoneft 239 tanker (in operation for more than 50 years) was damaged and went adrift during a storm on December 15, 2024. In general, the average period of operation of a ship in the Russian fleet is about 40 years.
- Unstable operation of the industry as a system as a whole. The Ministry of Industry and Trade clearly states that Russia's shipbuilding industry has been in transformation for the last decade [1], which is quite a long period of time which could have included the completion of a few investment cycles for innovative development. Moreover, researchers note that the industry had reached a critical state by the end of 2023 [6].
- The number of enterprises and capacities is inadequate for meeting the growing demand from transport companies. Expert estimates show that shipbuilders meet only 6% of the domestic demand for products [6]. The shortage of large-capacity ships is particularly high, as there are no production facilities for building such vessels and they cannot be added quickly. Russian ship owners acquire ships abroad. For example, eight new sea vessels were bought in 2022 and ten ships were acquired in 2023<sup>6</sup> [7]. According to experts, every month the Russian shadow tanker fleet is replenished with 10 vessels, most often used ones. By the end of 2024, this accounted for 9% of the global market [8]. The major-

<sup>5</sup> The Unified Plan for the Achievement of the National Development Goals of the Russian Federation for the Period until 2030 and in the Longer Run until 2036. URL: <http://static.government.ru/media/files/ZsnFICpxWknEXeTfQdmcFHNei2FhcR0A.pdf>

<sup>6</sup> Analysis of deliveries of vessels for sea transport fleet in 2023 / Central Marine Research and Design Institute (TsNIIMF). 21.03.2024. URL: <https://cniimf.ru/press-tsentr/news/1790/>

ity of studies note that the industry is expected to be highly overloaded in 2025–2030<sup>7</sup> and will be unable to fully meet the domestic demand [9].

- Use of outdated shipbuilding technologies with a significant production cycle and high cost of resources used [10]. The authors [9] emphasize that the Russian shipbuilding industry has almost no large-scale production where each order at a shipyard represents a unique, one-off product that has not been manufactured before and is unlikely to be ordered again. This makes the ship construction period longer, results in flaws during the ship creation process, etc. The level of automation is 7–9% (while in South Korea it is about 70%). It would be relevant to accelerate digitalization, i.e. to switch to Shipbuilding 4.0 using domestic software, which is almost non-existent given the specifics of the industry.
- Lack of highly skilled personnel. In 2023, the median wage in the industry was RUB 85,000 [11]. Apparently, industry offers quite difficult working conditions, especially for blue-collar jobs, and because of this non-competitive level of pay many specialists fulfil their potential in other, more comfortable occupations. Also worth noting is the existing uneven distribution of vacancies, the majority of which are found in certain regions (such as St. Petersburg, the Udmurt Republic, Primorsky Krai, Moscow, and Chelyabinsk Region).
- Growth of the key interest rate and inflation processes. In 2022–2024, the key interest rate of the Bank of Russia grew from 8% to 21%, i.e. 2.6 times, leading to an increase in the average weighted interest rates offered by credit institutions and an increase in loan debt. Hence, this directly affects the efficiency of lending which businesses need due to a significant duration of the building process. Official statistics show that the inflation rate was 11.92% in 2022, 7.42% in 2023, and 9.52% in 2024. Therefore, the financial resources budgeted both in the state budget and by shipbuilding companies turn out to be insufficient due to monetary depreciation, and when it comes to purchasing necessary equipment abroad, the cost of the currency for the purchase is steadily increasing. Inflation also affects the growth of the final cost of a ship.

Some of the key exogenous factors hampering the development of the industry include the following:

- Sanctions policy of unfriendly countries. In 2022, many European shipyards had to stop working with Russian shipbuilding and related companies. This mainly led to a decrease in supply of necessary equipment and parts. At the same time, this affected civil shipbuilding, but almost had no effects on military shipbuilding. In 2024 alone, the sanctions list was extended to include the following prohibitive measures: May 1: the U.S. Treasury's SDN List included shipbuilding projects of NOVATEK PJSC; June 12: the U.S. sanctions restricting access to software and specifically affecting more than 10 legal entities; June 25 and December 16: the 14th and 15th packages of EU sanctions aimed at a number of defence enterprises, shipping companies and supplies of products required for production.
- Deglobalization processes, the increasing numbers of international intermediaries, changes in international logistics and supply chains, which result in the increase in financial and time resources, leading to ships standing idle in docks waiting for necessary equipment and so on.

It is evident that in the current difficult conditions, the government should devote much attention to shipbuilding and provide appropriate financial support to the industry given its paramount strategic importance. This can take the form of the following operational measures:

- Subsidizing the construction of large-capacity ships;
- Financing some costs of disposing of and replacing old ships;
- Using financial leasing mechanisms for fleet renewal;
- Developing new marine equipment and modernization of enterprises.

Let us take a closer look at strategic documents aimed at developing and supporting the shipbuilding industry at the national level. According to Federal Law No. 172-FZ dated June 28, 2014 “On Strategic Planning in the Russian Federation”, Article 11, these documents include the Annual Presidential Address to the Federal Assembly, industry-specific strategic planning documents in terms of goals setting, and national projects (hereinafter “NPs”) and government-sponsored programmes (hereinafter “GPs”) in terms of planning and programming<sup>8</sup>.

The main areas of state policies for solving systemic socially significant problems are often set out in the

<sup>7</sup> Report on research “Studying the possibilities and limitations of the development of the shipbuilding (cargo and fishing vessels), ship repair and related industries in the context of sanctions pressure” / FANU VOSTOKGOSPLAN. Moscow, 2024. 413 p. URL: <https://vostokgosplan.ru/wp-content/uploads/issledovanie-vozmozhnostej-i-ogranichenij-razvitija-sudoostroitelnoj-i-sudoremontnoj-otraslej-v-uslovijah-sankcij-nir.pdf>

<sup>8</sup> Federal Law No. 172-FZ dated June 28, 2014 “On Strategic Planning in the Russian Federation” / Official website of legal information. URL: [www.pravo.gov.ru](http://www.pravo.gov.ru).

Concepts. For example, the draft of a new Concept for the Development of the Shipbuilding Industry in Russia, which is being worked on by the Krylov State Scientific Centre, is due in November 2026. Besides, this research centre has won a tender for the development of regulatory documents for standardization of shipbuilding, which currently count more than 3,000 documents. A separate law to regulate the industry is planned to be formulated by the end of 2025.

Meanwhile, it should be emphasized that the Concept is not mentioned in the Law “On Strategic Planning in the Russian Federation” as a strategic planning document. From the legal viewpoint, this does not allow for using it as the main regulatory act for strategic public management practices. Therefore, given that there are a number of various Concepts in force, there is a need for amending the Law. For example, the term “Concept” was established in the Federal Law No. 115-FZ dated July 20, 1995 “On State Forecasting and Programmes for Socio-Economic Development of the Russian Federation”, which has been in force since 1995.

In his Presidential Address to the Federal Assembly on February 29, 2024, Vladimir Putin, among other things, touched upon aspects of the development of transport in general and shipbuilding in particular. Thus, an emphasis was placed on reducing imports and switching to domestic production of vehicles. The completion of NOVATEK PJSC’s investment project to create the Murmansk Centre for Construction of Large-Capacity Marine Structures in the village of Belokamenka was highlighted as a large-scale achievement. The President emphasized the need for modernizing the backbone network of inland waterways and paid special attention to the development of the Northern Sea Route.

The document “On the Transport Strategy of the Russian Federation until 2030 with a Forecast until 2035” sets out strategic goals for the development of the entire transport sector of Russia and those related to spatial connectivity and accessibility, increasing mobility of population, volumes and speeds of cargo transit, digital and low-carbon transformation<sup>9</sup>. Based on the results of the 2023 Report on the Implementation of

the Transport Strategy, it should be noted that the performance indicators of the sea transport and seaports for the most part tend to increase compared to 2022, which is not the case with those on the performance of inland water transport and river ports<sup>10</sup>.

The Strategy for the Development of the Shipbuilding Industry for the Period until 2035 contains the main strategic goal for the formation of relevant shipbuilding products, along with the relevant tasks and priorities<sup>11</sup>. But in terms of strategic management, any strategy requires timely adjustment due to changes in external and internal factors which, as noted above, changed significantly in 2022–2024 alone.

The Strategy for the Development of the Shipbuilding Industry for the Period until 2035 was adopted in 2019 and its only amendment was dated October 21, 2024, and it is not related to the current realities in the industry. The authors’ research [12] based on the forecasting results has shown that effects of the current trends will not allow the industry to achieve the targets for the shipbuilding industry planned in the Strategy. The relevance of adjustment of this document is also emphasized in a research report<sup>12</sup> and in the Presidential Instruction to the Government dated March 14, 2024.

Besides, certain aspects of shipbuilding development are found in a fairly large number of other strategic government documents. For example, the Strategy for the Development of the Arctic Zone of the Russian Federation and Ensuring National Security until 2035 deals with issues related to the development of the Arctic and the Northern Sea Route.

The government-sponsored programme “The Development of Shipbuilding and Equipment for the Development of Offshore Deposits” (GP-18) approved on April 15, 2014 divided the implementation period into two stages: Stage I in 2013–2021 and Stage II in 2022–2030. The document contains goals and indicators that are almost completely the same as those stated in the Strategy for the Development of the Shipbuilding Industry until 2035. However, GP-18 does not take into account the objective referred to in the Transport Strategy for the construction and commissioning of more than 1,000 passenger and cargo ves-

<sup>9</sup> “On the Transport Strategy of the Russian Federation until 2030 with a Forecast until 2035”, approved by Order of the Government of the Russian Federation No. 3363-r dated November 27, 2021. URL: <https://docs.cntd.ru/document/727294161>

<sup>10</sup> Report on the Implementation of the Transport Strategy of the Russian Federation until 2030 with a Forecast until 2035. Reporting period: 2023 / Ministry of Transport of the Russian Federation. URL: <https://mintrans.gov.ru/documents/11/13540?type=11>

<sup>11</sup> Strategy for the Development of the Shipbuilding Industry for the Period until 2035, approved by Order of the Government of the Russian Federation No. 2553-r dated October 28, 2019. URL: <https://docs.cntd.ru/document/563615576>

<sup>12</sup> Report on research “Studying the possibilities and limitations of the development of the shipbuilding (cargo and fishing vessels), ship repair and related industries in the context of sanctions pressure” / FANU VOSTOKGOSPLAN. Moscow, 2024. 413 p. URL: <https://vostokgosplan.ru/wp-content/uploads/issledovanie-vozmozhnoej-i-ogranichenij-razvitija-sudostroitelnoj-i-sudoremontnoj-otraslej-v-uslovijah-sankcij-nir.pdf>

Table 2

Financial provision of GP “The Development of Shipbuilding and Equipment for the Development of Offshore Deposits”,  
RUB million<sup>13,14</sup>

Indicator	Period				
	2023	2024	2025 (plan)	2026 (plan)	2027 (plan)
FP “Production of Ships and Marine Equipment”	–	–	<b>28,156.3</b>	<b>57,606.7</b>	<b>98,329.7</b>
FP “Stimulating Demand for Domestic Shipbuilding Products”	29,649.5	<b>31,791.0</b>	<b>135.5</b>	<b>135.9</b>	<b>135.9</b>
FP “Development of Large-Capacity Shipbuilding”	18,187.0	6,557.9	0	0	0
DP “A New Look of the Shipbuilding Industry”	207.0	207.0	0	0	0
Total	48,043.5	38,555.9	<b>28,291.8</b>	<b>57,742.6</b>	<b>98,465.6</b>

sels to replace retired worn-out and obsolete ships in 2019–2035. Besides, the Programme was not adjusted to be in line with the Presidential Address. In general, the monitoring of GP-18 in 2022–2023 showed the achievement of its targets<sup>15</sup>. Budget allocations to structural elements of the Programme in the form of national, federal (FP) and departmental projects (DP) are shown in *Table 2*.

As can be seen in *Table 2*, from 2026 onwards, it is planned to significantly increase funding for GP-18: by more than 2 times, and in 2027 it will be increased by 3.5 times compared to 2025. But, for example, in 2023, a much larger amount of budget funds was spent on the Programme than planned for 2025. It should also be noted that initially, the amount allocated for 2023 was almost 2 times less, but it was increased during the year.

GP “Environmental Protection” contains FP “The Development of Research and Distant-Water Fleet”, allocations to which are planned at RUB 6,341.7 million in 2025, RUB 3,916.6 million in 2026, and RUB 9,941.7 million in 2027<sup>16</sup>.

The data on allocations from the budget for the development of military shipbuilding is classified information and therefore cannot be included in this study.

The state budget for 2025–2027 provides for funding of R&D activities, including their systemic, analytical and expert support, operations to modernize production facilities, and subsidies for shipbuilding companies and related enterprises.

## CONCLUSION AND DISCUSSION

As follows from the data presented above, the total planned amount of state funding for civil shipbuilding in Russia within the framework of the above-mentioned GPs and NPs in 2025–2027 will be at least RUB 204.7 trillion. A fairly large portion of the budget will also be allocated to military shipbuilding within the framework of the defence procurement programme, which will have a positive effect on both the industry and its related areas.

Based on strategic positions, in general, we can state that the government pays quite significant attention to the industry both in terms of financial support and its long-term planning and further development. However, the authors believe that a number of additional actions need to be taken to improve the public management processes to manage the development of shipbuilding.

1. The first aspect involves finalizing the Law “On Strategic Planning in the Russian Federation”. From the perspective of strategic management, planning is only one of its stages. Accordingly, a sound strategic public management process should not only include planning as an element, but also operational management itself including control and assessment of the implementation of strategies as its component parts. The Law contains generalized procedures for monitoring and control of strategies, i.e. the document is much broader than its title. But these procedures lack detail and their

<sup>13</sup> Opinion of the Accounts Chamber of the Russian Federation on the 2023 Federal Budget Performance Report. URL: <https://ach.gov.ru/upload/iblock/408/1ya157v6llliuulgrbvzpnbn4n1newb.pdf>

<sup>14</sup> Federal Law No. 419-FZ dated November 30, 2024 “On the Federal Budget for 2025 and for the Target Period of 2026 and 2027”. URL: <http://actual.pravo.gov.ru>

<sup>15</sup> Opinion of the Accounts Chamber of the Russian Federation on the 2023 Federal Budget Performance Report. URL: <https://ach.gov.ru/upload/iblock/408/1ya157v6llliuulgrbvzpnbn4n1newb.pdf>

<sup>16</sup> Federal Law No. 419-FZ dated November 30, 2024 “On the Federal Budget for 2025 and for the Target Period of 2026 and 2027”. URL: <http://actual.pravo.gov.ru>

implementation mechanisms are not specified, which leads to ambiguity in understanding them in practical terms. It is necessary to have a legislated procedure in place for timely adjustment of adopted Strategies following both external and internal changes. In addition, as stated above, the Law should include the term “Concept”.

2. It is necessary to tighten procedures to monitor and control spending of special-purpose funds and ensure efficient achievement of the strategic goals and objectives set. In the late 2024, the President of Russia instructed the Accounts Chamber to audit the completed NPs operated in the period from 2019 to 2024 by June 01, 2025<sup>17</sup>. It is the first time that such a large-scale audit has been undertaken (previously, monitoring procedures of this kind were only carried out as part of criminal cases) and it will identify systemic problems and flaws in the implementation of government-sponsored projects, which will result in the adjustment of a number of legislative and regulatory acts, beginning with the Law “On Strategic Planning in the Russian Federation”. In order to improve these procedures during the implementation of the existing strategic docu-

ments, it is also necessary to consistently reduce their overall numbers. As of the end of 2024, the “Management” State Automated Information System (GAIS) has a document register with about 59,000 regulatory and legal acts on strategic planning of all levels. Obviously, many of these documents are not interrelated and it is extremely difficult to effectively and timely monitor the achievement of strategic goals and objectives set out in such a number of documents.

3. In strategic management of the corporate sector, full responsibility of top management members for failures and non-achievement of long-term goals and objectives set earlier is clearly regulated. In strategic public management, this aspect also requires more transparency, detail and consistency in toughening punishment both for civil servants and heads of state corporations and companies with state participation.

We would also like to note that the historical experience of the post-war USSR in shipbuilding shows that Russia is able to stay focused, overcome all negative endogenous factors, and restore its technological leadership in this industry, which is a strategic necessity in the present context.

## REFERENCES

1. Russian shipbuilding today and tomorrow / Department of shipbuilding industry and marine engineering of the Ministry of Industry and Trade of Russia. June 26, 2024. *Marine Collegium*. URL: <https://marine.org.ru/upload/iblock/5f1/irnf5z92d6o46gq6t-k0qopdxtubsggh.pdf>. (In Russ.).
2. Russian shipyards increased the number of delivered vessels by 36%, INFOLine notes. 28.02.2024. URL: <https://infoline.spb.ru/news/index.php?news=284501&ysclid=lv4n42ltmf942657874>. (In Russ.).
3. Sidorov A. Shipbuilding of Russia: the fleet is counted in the fall. *Maritime News of Russia*. 21.11.2024. URL: <https://morvesti.ru/analitika/1692/112715/>. (In Russ.).
4. Kvasnikova E.A. Macroeconomic determinants of the civil shipbuilding development: global trends and prospects of Russian manufacturers. *Russian Journal of Innovation Economics*, 2022;12(3):1817-1832. URL: <https://doi.org/10.18334/vinec.12.3.115077>. EDN VPPLVH. (In Russ.).
5. Konovalov S. There are many problems in shipbuilding. We will solve them together / *Mediadeck*. 26.02.2024. URL: <https://paluba.media/news/71450>. (In Russ.).
6. Sergeev K. Shipbuilding in Russia: from program to plan. *Shipbuilder*. 30.05.2024. URL: [https://www.korabel.ru/news/comments/sudostroenie\\_rossii\\_ot\\_programmy\\_-\\_k\\_planu.html](https://www.korabel.ru/news/comments/sudostroenie_rossii_ot_programmy_-_k_planu.html). (In Russ.).
7. Specialists of JSC Central Research and Design Institute of the Marine Fleet conducted an analysis of deliveries of sea transport vessels for domestic ship owners in 2022 / Central Research and Design Institute of the Marine Fleet. 17.03.2023. URL: <https://cni-imf.ru/press-tsentr/news/1632/#anc1>. (In Russ.).
8. Shchukin P. The growth of the Russian shadow fleet of tankers has been calculated. *Lenta*. 17.12.2024. URL: <https://lenta.ru/news/2024/12/17/prirost/>. (In Russ.).
9. Savchenko O.V., Polovinkin V.N. The current state, problems and prospects of domestic commercial shipbuilding. *Transactions of the Krylov State Research Centre*. 2022;3(401):152-164. DOI: 10.24937/2542-2324-2022-3-401-152-164. EDN KQCNFY. (In Russ.).
10. Kozhina E.V., Schislyaeva E.R. Key problems on the way of digital transformation of Russian shipbuilding. *Beneficium*. 2023;1(46):DOI: 10.34680/BENEFICIUM.2023.1(46).28-35. (In Russ.).
11. “The labor shortage will remain a fundamental problem of the labor market in 2024” – the results of 2023 in the country's shipbuilding industry. *Media deck*. 02.02.2024. URL: <https://paluba.media/news/69112>. (In Russ.).
12. Tresoruk A.A., Frolov I.E. Long-term development of Russian shipbuilding taking into account the processes of diversification of defense industries: model and forecast. *Problems of forecasting*. 2020;6(183):119-128. DOI: 10.47711/0868-6351-183-119-128. (In Russ.).

<sup>17</sup> The Accounts Chamber announces 113 activities to audit completed national projects // *Vedomosti* 11.02.2025. URL: <https://www.vedomosti.ru/society/articles/2025/02/11/1091324-schetnaya-palata-anonsirovala-113-meropriyati>

## ЛИТЕРАТУРА

1. Российское судостроение сегодня и завтра / Департамент судостроительной промышленности и морской техники Минпромторга России. 26 июня 2024 г. // Морская коллегия. URL: <https://marine.org.ru/upload/iblock/5f1/irmfb5z92d6o46gq6tk0qopdxtdubsggh.pdf>.
2. Российские верфи увеличили число сданных судов на 36%, отмечают в INFOLine // INFOLine. URL: <https://infoline.spb.ru/news/index.php?news=284501&ysclid=lv4n42ltmf942657874>.
3. Сидоров А. Судостроение России: флот по осени считают // Морские вести России. 21.11.2024. URL: <https://morvesti.ru/analitika/1692/112715/>.
4. Квасникова Е.А. Макроэкономические детерминанты развития гражданского судостроения: мировые тренды и перспективы российских производителей // Вопросы инновационной экономики. 2022. Т. 12. № 3. С. 1817–1832. DOI: 10.18334/vines.12.3.115077. EDN VPPLVH.
5. Коновалов С. Проблем в судостроении много. Решать их будем вместе // Медиапалуба. 26.02.2024. URL: <https://paluba.media/news/71450>.
6. Сергеев К. Судостроение России: от программы — к Плану // Корабел. 30.05.2024. URL: [https://www.korabel.ru/news/comments/sudostroenie\\_rossii\\_ot\\_programmy\\_-\\_k\\_planu.html](https://www.korabel.ru/news/comments/sudostroenie_rossii_ot_programmy_-_k_planu.html).
7. Специалисты АО «ЦНИИМФ» провели анализ поставок судов морского транспортного флота для отечественных судовладельцев за 2022 год // ЦНИИМФ. 17.03.2023. URL: <https://cniimf.ru/press-tsentr/news/1632/#anc1>.
8. Щукин П. Подсчитан прирост российского теневого флота танкеров // Лента. 17.12.2024. URL: <https://lenta.ru/news/2024/12/17/prirost/>.
9. Савченко О.В., Половинкин В.Н. Современное состояние, проблемы и перспективы развития отечественного гражданского судостроения // Труды Крыловского государственного научного центра. 2022. № 3 (401). С. 152–164. DOI: 10.24937/2542-2324-2022-3-401-152-164. EDN KQCNFY.
10. Кожина Е.В., Счисляева Е.Р. Ключевые проблемы на пути цифровой трансформации российского судостроения // Beneficium. 2023. № 1 (46). С. 28–35. DOI: 10.34680/BENEFICIUM.2023.1(46).28-35.
11. «Дефицит кадров останется фундаментальной проблемой рынка труда в 2024» — итоги 2023 года в судостроительной отрасли страны // Медиапалуба. 02.02.2024. URL: <https://paluba.media/news/69112>.
12. Тресорук А.А., Фролов И.Э. Долгосрочное развитие российского судостроения с учетом процессов диверсификации оборонных отраслей: модель и прогноз // Проблемы прогнозирования. 2020. № 6 (183). С. 119–128. DOI: 10.47711/0868-6351-183-119-128.

## Bionotes

**Nataliya E. Tereshkina** — Cand. Sci. (Econom.), Associate Professor, Associate Professor of the Department of Transport Management; **Siberian Transport University (STU)**; 191 Dusi Koval'chuk st., Novosibirsk, 630049, Russian Federation; SPIN-code: 6214-4430, RSCI ID: 879602, ResearcherID: ABT-9293-2022, ORCID: 0000-0002-1303-8871; [phd\\_76@mail.ru](mailto:phd_76@mail.ru);

**Ol'ga A. Khalturina** — Cand. Sci. (Econom.), Associate Professor, Associate Professor of the Department of Information and Analytical Support and Accounting; **Novosibirsk State University of Economics and Management (NSUEM)**; 56 Kamenskaya st., Novosibirsk, 630099, Russian Federation; RSCI ID: 709077, SPIN-code: 8402-0899, ORCID: 0000-0001-6264-3042; [olga\\_andre@mail.ru](mailto:olga_andre@mail.ru).

## Об авторах

**Наталья Евгеньевна Терешкина** — кандидат экономических наук, доцент, доцент кафедры «Менеджмент на транспорте»; **Сибирский государственный университет путей сообщения (СГУПС)**; 630049, Россия, г. Новосибирск, ул. Дуси Ковальчук, д. 191; SPIN-код: 6214-4430, РИНЦ ID: 879602, ResearcherID: ABT-9293-2022, ORCID: 0000-0002-1303-8871; [phd\\_76@mail.ru](mailto:phd_76@mail.ru);

**Ольга Альбертовна Халтурина** — кандидат экономических наук, доцент, доцент кафедры Информационно-аналитического обеспечения и бухгалтерского учета; **Новосибирский государственный университет экономики и управления (НГУЭУ)**; 630099, Россия, г. Новосибирск ул. Каменская, д. 56; РИНЦ ID: 709077, SPIN-код: 8402-0899, ORCID: 0000-0001-6264-3042; [olga\\_andre@mail.ru](mailto:olga_andre@mail.ru).

Contribution of the authors: the authors contributed equally to this article.

The authors declare no conflicts of interests.

Заявленный вклад авторов: все авторы сделали эквивалентный вклад в подготовку публикации.

Авторы заявляют об отсутствии конфликта интересов.

Corresponding author: Nataliya E. Tereshkina, [phd\\_76@mail.ru](mailto:phd_76@mail.ru).

Автор, ответственный за переписку: Наталья Евгеньевна Терешкина, [phd\\_76@mail.ru](mailto:phd_76@mail.ru).

The article was submitted 22.07.2025; accepted for publication 28.08.2025.

Статья поступила в редакцию 22.07.2025; принята к публикации 28.08.2025.

## Report

UDC 625.3.03:656.22(091)

doi: 10.46684/2025.3.06

EDN EYPRUL

## High-speed railway. Effect of previous successful designers<sup>1</sup>

**Igor P. Kiselev**

Emperor Alexander I St. Petersburg State Transport University (PGUPS); Saint Petersburg, Russian Federation; kiselev@pgups.ru

**ABSTRACT** The paper examines the origins of scientific and engineering approaches to design and construction of public railways in the 19th century. The underdeveloped engineering and technologies of the time severely constrained the aspirations of designers and builders to reduce the length of the railway route. The high-speed railways (HSR) that began to be built in the 1960s were created in new engineering and technological conditions. The paper compares the characteristics of a number of railways built in the 19th century and high-speed railways of the 20th century. Some of the major railway lines built in the 19th century have high technical performance, such as a straight route. For example, the parameters of the 650 km long St. Petersburg–Moscow Railway<sup>2</sup> built in 1851 allowed for the arrangement of high-speed traffic (up to 250 km/h) after the reconstruction of its facilities without fundamentally altering the horizontal and vertical alignment.

**KEYWORDS:** route; railway vertical and horizontal alignments; route development ratio; high-speed railway; rail bypass; slope gradient; HSR; Sapsan EMU

**For citation:** Kiselev I.P. High-speed railway. The effect of previous successful designers. *BRICS transport*. 2025;4(3):06. <https://doi.org/10.46684/2025.3.06>. EDN EYPRUL.

## Доклад

## Высокоскоростная железная дорога. Эффект работы предыдущих успешных проектировщиков<sup>1</sup>

**И.П. Киселев**

Петербургский государственный университет путей сообщения Императора Александра I (ПГУПС), г. Санкт-Петербург, Российская Федерация; kiselev@pgups.ru

**АННОТАЦИЯ** Рассмотрено зарождение научно-инженерных подходов к проектированию и строительству железных дорог общего пользования в XIX в. Недостаточное развитие техники и технологии того времени накладывало серьезные ограничения на стремление проектировщиков и строителей сократить длину трассы железных дорог. Высокоскоростные железнодорожные магистрали (ВСМ), строительство которых началось в 1960-е гг., создавались в

<sup>1</sup> The full text of the report presented by the author in a condensed version at the 12th World Congress on High-Speed Rail in Beijing on July 8, 2025.

Полный текст доклада, прочитанного автором в сокращенном варианте 8 июля 2025 г. на XII всемирном конгрессе по высокоскоростному железнодорожному движению в Пекине.

<sup>2</sup> This was the name of the railway before September 8 [20], 1855. After the death of Emperor Nicholas I on February 18 [March 2], 1855, it was renamed Nikolaevskaya. On February 27, 1923, People's Commissar of Railways Felix Dzerzhinsky issued Order No. 1313 that renamed the Nikolaevskaya Railway into the October Railway. This is the only name of a railway in Russia, and one of the few in the world, that is not based on administrative division and/or a geographic location, toponym, or the name of a personality. The October Railway was named after the October Socialist Revolution in Russia that took place on October 25 [November 7 in the new style calendar], 1917. Dates up to January 31, 1918 are given according to the Julian calendar (known as the "old style"); the later dates are given in brackets according to the Gregorian calendar which was introduced in Russia on February 14, 1918 (the so-called "new style").

новых технико-технологических условиях. Приведены сравнительные характеристики ряда железных дорог, построенных в XIX в. и ВСМ XX в. Среди крупных железных дорог, сооруженных в XIX в., есть примеры магистралей с высокими техническими характеристиками, в частности, отличающихся прямолинейностью трассы. Так, параметры построенной в 1851 г. Петербурго-Московской железной дороги длиной 650 км позволили после проведенной реконструкции технических устройств, но без кардинального переустройства плана и профиля, организовать на ней высокоскоростное движение (до 250 км/ч).

**КЛЮЧЕВЫЕ СЛОВА:** трасса; продольный профиль и план железной дороги; коэффициент развития трассы; высокоскоростная железнодорожная магистраль; железнодорожный обход; крутизна уклона; ВСМ; «Сапсан»

**Для цитирования:** Киселев И.П. Высокоскоростная железная дорога. Эффект работы предыдущих успешных проектировщиков // Транспорт БРИКС. 2025. Т. 4. Вып. 3. Ст. 06. <https://doi.org/10.46684/2025.3.06>. EDN EYPRUL.

## INTRODUCTION

The construction of railways on a broad scale in England and then in other countries is known to have started with the launch and subsequent successful operation of the Stockton and Darlington, the world's first public railway, on May 27, 1825. The implementation of the project was led by businessman Edward Pease (1767–1858) and outstanding engineer, “Father of Railways”, George Stephenson (1781–1848). The success of the railway furthered with the construction of the first fully steam-powered railway between Manchester and Liverpool in 1830.

With the beginning of construction of the first railways in the world, the length of the rail line (the total distance of the main line) has been one of the major parameters, along with the route, vertical alignment, maximum gradient, and minimum horizontal and vertical curve radii. It is not just the length, but the length adjusted by the so-called “route development (elongation) ratio” taken to mean the ratio of the length of the main line to the geodetic line. For Russian railways, the development ratio is taken within the range of 1.1–1.25 for moderate conditions and is increased to 1.5 and higher for severe conditions [1]. The route development ratio is one of the criteria for assessing the quality of the design and survey work performed.

In the early to mid-19th century, when the first railways were built, the designers' efforts to shorten the length of the railway route, bringing it closer to the geodetic line, was strongly constrained by the state of the art in engineering and railway design and construction methods. Curved track sections, often sharp ones, appeared on the route due to the need to bypass natural obstacles, or, in some cases, the impossibility of building bridge or tunnel crossings over water bodies, hills or mountains, or because of excessive building costs. Besides, in the infancy of railway construction, the reduction of the route length was hampered by the low capacity of steam engines unable to overcome steep slopes in the terrain.

Because of all of the factors listed above, the route had to be extended (lengthened) by designing easy gradients with additional curved sections to bypass sharp rises on a hilly or mountainous terrain, which limited the speed of trains — one of the major railway performance parameters.

## ERA OF HIGH-SPEED RAILWAYS

The construction of high-speed railways (HSR) in the second half of the 20th century took place in a different engineering and technology paradigm. Designed for travels at speeds exceeding 200–250 km/h, HSR have larger minimum horizontal curve radii — since the 1960s, their values have increased up to 7,000–10,000 m. It necessitated building intersections with other transport lines at different levels, and the number of man-made structures per unit of railway length has increased significantly. As a result, most HSRs built in the second half of the 20th century parallel to the existing railways are shorter than the latter.

For example, on the world's first HSRs Tokaido Shinkansen and Sanyo Shinkansen in Japan built in the 1960–1970s, the length of the line between Tokyo and Kobe stations is 548 km (*Fig. 1, 2, Table 1*), while the length of the railway built between the two in the 19th century is 589.5 km (41.5 km longer) [2].

Another example is the Direttissima (Direct Line), a high-speed rail route between Rome and Florence in Italy (built in 1977–1992), which is 238 km long, while the length of the **Linea Lenta** railway between the same cities built in 1871 is 372 km [3].

Nevertheless, the world knows examples of railways built as early as the mid-19th century, their main design solutions still preserving their basic parameters even now, 150–170 years after: the route location, maximum gradient values, minimum curve radii, and others, allowing for accommodating traffic at speeds of 200–250 km/h after upgrading of certain

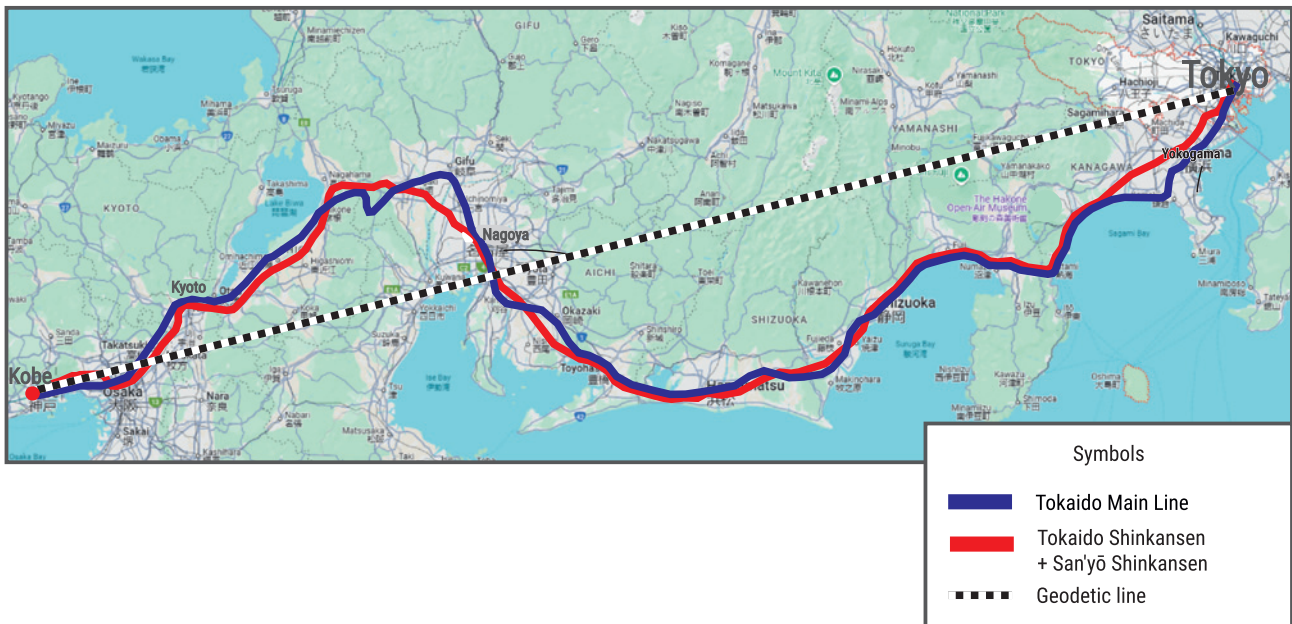

Fig. 1. Comparison of the route lengths of the Tokaido Shinkansen and Sanyo Shinkansen HSRs with the geodetic line

Table 1

Length of some railways and HSRs

Railway built before HSR ("Old") HSR	Opening year		Length, km		Geodetic length, km	Max. speed, km/h
	"Old"	HSR	Route development ratio			
			"Old"	HSR		
Tokaido Main Line Tokyo–Kobe [2]	1872		$\frac{589}{1.3}$		430	75
Tokaido Shinkansen HSR + Sanyo Shinkansen HSR: Tokyo–Kobe [3]		1964–1972		$\frac{548}{1.27}$		285
Paris–Lyon (Paris–Marseille) [3]	1847		$\frac{499,8}{1.27}$		390.5	100
Paris–Lyon HSR (LGV Sud-Est) [3]		1981		$\frac{425}{1.08}$		300
Rome–Florence (Linea Lenta, LL) [3]	1871		$\frac{372}{1.4}$		232.3	100
Rome–Florence HSR (Direttissima, DD) [3]		1977–1992		$\frac{238}{1.02}$		250
Madrid–Barcelona (Atocha Train Station) [3]	1882		$\frac{699,7}{1.39}$		501.6	80
Madrid–Barcelona HSR (Chamartin Train Station) [3]		2008		$\frac{620}{1.23}$		350
Beijing–Shanghai (old railway line) [3]	1896–1936–2005	2011	$\frac{1451}{1.36}$		1060	160
Beijing–Shanghai [3]				$\frac{1302}{1.22}$		380
St. Petersburg–Moscow (1851) [4]	1851		$\frac{644.4}{1.01}$		637.94	1851 – 50
– 1851–1881			$\frac{649}{1.02}$			2025 – 250
– 1881–2001			$\frac{644.4}{1.01}$			
– 2001–present				$\frac{679}{1.07}$		
Moscow–St. Petersburg HSR [5]		Design				360

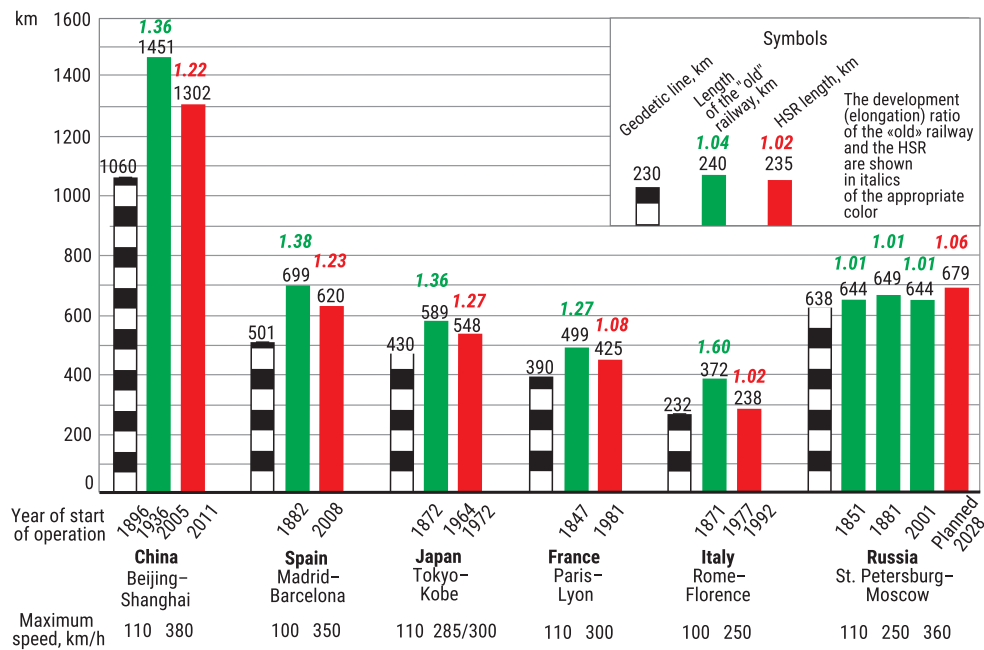

Fig. 2. Comparison of lengths of ordinary railways and HSR for a number of routes

infrastructure elements (without changing the basic design parameters).

One of these examples is Russia’s first (and one of the world’s first) long (more than 600 km) double-track railway line between St. Petersburg and Moscow which was put into operation in 1851.

The first 27-km long public railway between St. Petersburg and its suburban settlement Pavlovsk was built in Russia 14 years earlier. The line was built and put into operation by Austrian engineer Franz Anton von Gerstner. All the personnel, including designers, construction managers, as well as locomotive drivers and conductors, were foreigners invited to work in Russia.

However, just five years later, the design and construction of the first main railway line St. Petersburg–Moscow<sup>3</sup> was carried out by Russian engineers, the graduates of the first engineering institute in Russia: the Institute of the Corps of Transport Engineers (IKIPS) which was opened in 1809.

Within a historically short period of time, less than 10 years, graduates of this educational institution mastered the scientific basics and techniques of railway systems and railway construction, and developed ad-

vanced technologies for railway transport, one of the most important components of the industrial revolution, as applied to Russia’s conditions.

Designing the St. Petersburg–Moscow railway involved making the first important scientific and technical decisions and determining the design parameters and principles for construction management and operation of the future main line. The process also included developing socio-economic and political criteria for decision-making in the field of emerging railway transport, in particular, such important ones as choosing directions of future railways.

According to historical records, the leaders of the project for construction of the St. Petersburg–Moscow Railway, engineers Pavel Melnikov and Nikolai Kraft were under moral and political pressure on the part of some ministers, other officials and business executives, who wanted to persuade them into building the line via Veliky Novgorod — the country’s important historical, cultural and trade centre of the time located 190 km away from St. Petersburg (Fig. 3).

When St. Petersburg was founded as a new capital of Russia in 1703, a beaten trail via Veliky Novgorod

<sup>3</sup>This was the name of the railway before September 8 [20], 1855. After the death of Emperor Nicholas I on February 18 [March 2], 1855, it was renamed Nikolaevskaya. On February 27, 1923, People’s Commissar of Railways Felix Dzerzhinsky issued Order No. 1313 that renamed the Nikolaevskaya Railway into the October Railway. This is the only name of a railway in Russia, and one of the few in the world, that is not based on administrative division and/or a geographic location, toponym, or the name of a personality. The October Railway was named after the October Socialist Revolution in Russia that took place on October 25 [November 7 in the new style calendar], 1917. Dates up to January 31, 1918 are given according to the Julian calendar (known as the “old style”); the later dates are given in brackets according to the Gregorian calendar which was introduced in Russia on February 14, 1918 (the so-called “new style”).



**Fig. 3.** Map of directions of railways, highways and water ways between St. Petersburg and Moscow  
The map shows the line of the St. Petersburg–Moscow railway under construction. With supplements by Igor P. Kiselev<sup>4</sup> [6]

formed between the city and Moscow. By the early 19th century, after some construction work, the condition of the trail improved and it was turned into a 719 km long main road. Its route deviated from the shortest path and exceeded the geodetic line by more than 85 km (Fig. 3). The above mentioned influential political and economic establishment of the country lobbied the layout repeating the path of this very road when building the railway.

Pavel Melnikov and Nikolai Kraft stood up for building the railway line without going to Veliky Novgorod and were supported by Emperor Nicholas I who made the final strategic decision regarding the route of the future railway line to follow a direct path [7].

The length of the fully completed railway line which was put into operation on November 1 [13], 1851 was 644.4 km<sup>5</sup> [7], and the development ratio was 1.01, which is a great value for a railway. In general, the good quality of the design and construction of the St. Petersburg–Moscow line was, indeed, technically among the world's best results of the time, which was confirmed by its operation.

The St. Petersburg–Moscow Railway was put into operation in sections, on which regular services started in 1846. The technical parameters of the railway line were worked out and then implemented so thoroughly that further allowed fast increase of its capacity, increasing both the passenger and cargo traffic and travel speeds.

From the beginning, the railway line was built with two tracks of 5 ft (1,524 mm) gauge, which subsequently became the standard for the Russian Empire. Its vertical alignment contained balanced slopes in both freight-hauling (towards St. Petersburg) and passenger (towards Moscow) directions: 2.5 ‰ and 5 ‰, respectively. The line was distinguished by its straightness: it was 644.4 km long, which was just 7.4 km longer than the geometrically straight line by air. The minimum curve radius was 1,600 m on running lines, and 1,065 m at operation points. The embankments built on swamps were filled down to the mineral bed. The bridges on the line were built to the then best design proposed by transport engineer Dmitry Zhuravsky. The station buildings were built to standard designs [7].

<sup>4</sup> <https://expositions.nlr.ru/ve/RA4367/ot-parovoza-do-sapsana>.

<sup>5</sup> The geodetic line is 637.9 km [2]; the difference is 6.4 km (about 1 %).

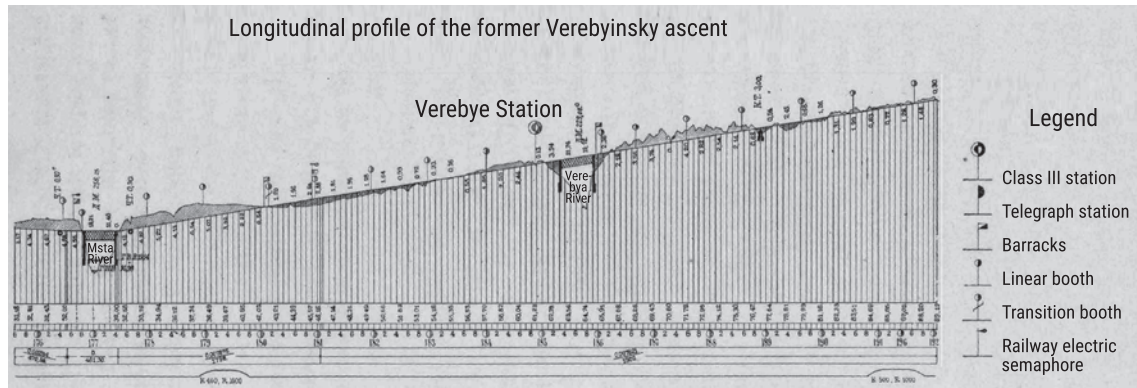

Fig. 4. Longitudinal profile of the former Verebyinsky ascent. 1851 [9, P. 116]

At the same time, problems began to show up when the operation of the St. Petersburg–Moscow Railway began. It revealed discrepancies between the levels of development of individual components of the whole transport system known as a railway. For example, the capacity of the steam locomotives used on the railway being, undoubtedly, among the world's best of the time, and the design of the brake systems on railway rolling stock did not meet the designed parameters and infrastructure elements which allowed for much higher travel speeds and train weights than the available rolling stock was able to provide.

The construction of the St. Petersburg–Moscow Railway was certainly a feat of a galaxy of brilliant transport engineers, railway managers, and operating staff who organized the train traffic on such a long rail line, as well as thousands of unknown builders and workers, including workers of the Alexandrovsky Plant.

It is important to note that the problems emerging with the commencement of the operation were successfully solved. The St. Petersburg–Moscow Railway has always been, and still remains, a technically ad-

vanced one in the Russian railway network, featuring the highest travel speeds. Enabling train speeds of up to 250 km/h, today it can be rightfully classified as a high-speed railway.

Following the desire to create a straight route between St. Petersburg and Moscow, with the length approaching the geodetic one, to ensure the highest possible speed and reduce the amount of construction (earthworks), and given the rising terrain from the bank of the Msta River, the designers made a long ascending grade for 15.5 km at the 177th–192nd verst (189–204 km) from St. Petersburg in the direction towards Moscow (Fig. 4). For this climb, the line's highest gradient of 7.8 ‰ was adopted, which is higher than the maximum gradient of 5 ‰ on the passenger direction of the railway as a whole [7].

On the long ascent, the railway line crossed a deep and wide ravine formed by the Verebya River. Based on the engineering and economic comparison of the options of building a bridge or a high embankment, it was decided to build a bridge across the ravine (Fig. 5).

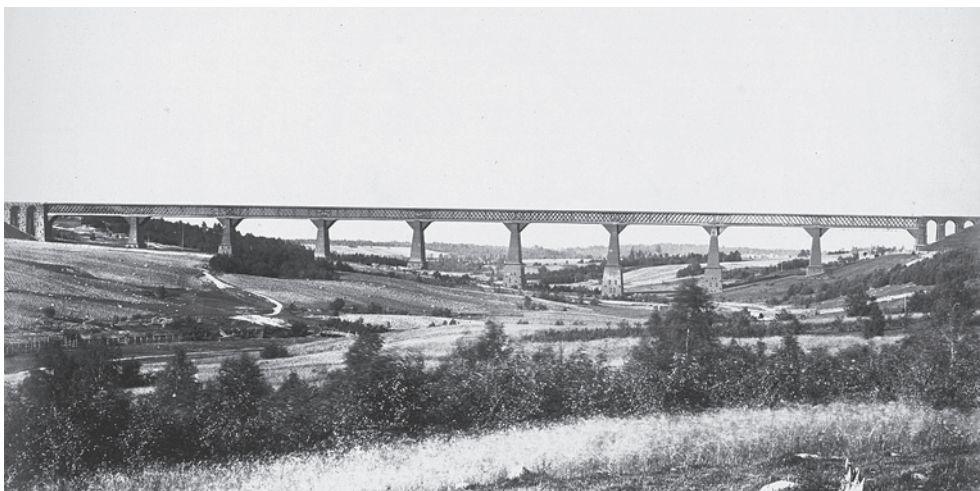

Fig. 5. Bridge across Verebyinsky Ravine. Postcard of the 19th century. Science and Technology Library of Emperor Alexander I St. Petersburg State Transport University (NTB PGUPS)

Pavel Melnikov assigned the project to Dmitry Zhuravsky, a graduate of the Institute of the Corps of Transport Engineers, young transport engineer, who subsequently became a prominent scientist in the field of bridge construction engineering.

Under the guidance of George Washington Whistler (1800–1849), an American engineer, the project's "engineering adviser", Dmitry Zhuravsky used a bridge truss designed by American engineer William Howe (1803–1852) and built from timber and steel tie rods (tension bars: metal strips or rods) [8].

At the instructions of Pavel Melnikov, Dmitry Zhuravsky re-tested the Howe truss theoretically, improved it and confirmed the correctness of his findings experimentally. He proved that the closer to abutments, the higher the load on verticals and diagonals, and proposed making truss elements of different thickness based on their location by reducing the cross-section of the tie rods closer to span centres. As a result, one of the first scientifically-based methods for the design of bridge trusses was proposed (1850). Whistler supported the proposals by Zhuravsky and they were used to build all bridges on the railway line [8].

Built in 1851, the Verebyinsky Bridge had nine spans with 49.7 m long wooden trusses resting on eight wooden abutments with a stone foundation and seven stone coastal arches 6.4 m each (Fig. 5). The height from the water to the level of the railway track was 50 m. The bridge was operated until 1881<sup>6</sup> [8]. Outstanding Russian bridge engineer Stanislav Kerbedz, who built the first permanent bridge across the Neva River in St. Petersburg in 1850 and the first bridge with trussed metal girders across the Luga River on the St. Petersburg–Warsaw Railway in 1856, emphasized, "Before Dmitry Ivanovich Zhuravsky, bridge construction was a mystery; after him it became an engineering science" [10]. In Russia, bridges built to the design improved by Zhuravsky are known as the Howe–Zhuravsky system.

Meanwhile, the first months of regular train traffic on the railway line in 1851 already showed that traveling on this long ascent (descent) was dangerous. Emergency situations repeatedly occurred due to the

unreliable performance, alas, of the hand brakes installed in carriages, the best available at the time<sup>7</sup>. On the long descent on the way from Moscow, the train crews would sometimes be unable to stop the train and it would pass Mstinsky Most Station without stopping. To avoid accidents, the station master made sure that by the time the train arrived from Moscow, the previous train going towards St. Petersburg had already left for the 8-km long Mstinsky Most–Burga section in good time. Fortunately, those incidents did not have disastrous consequences.

On the other hand, when traveling towards Moscow with a full freight train, steam engines were not always able to surmount the long ascent. Trains had to be uncoupled into two parts at Burga station, and each was then delivered by a separate steam locomotive to Torbino station where they were recombined into a single train to proceed to Moscow.

On February 12, 1862, a freight train going from St. Petersburg to Moscow was uncoupled at Malaya Vishera station. The first half was delivered to Verebye station located on a slope towards St. Petersburg<sup>8</sup> and then "*uncoupled from the machine*". Several carriages left at Verebye station went downhill on the running line towards St. Petersburg as they were poorly secured to the track (stove wood was placed under the wheels, as brake shoes had not yet been invented). They passed Mstinsky Most station and collided with a train pulled by locomotive No. 515, which was hauling the second part of the uncoupled train from Vyshny Volochok station. Six people died and several were injured. The incident was thoroughly investigated, resulting in studying the issue of placing stations on horizontal sections and of devices required to secure carriages uncoupled from locomotives [11].

In 1874, a routine inspection revealed an irreversible deterioration in the condition of the Verebyinsky Bridge that occurred over the 24 years of its operation. It was acknowledged that further operation of the Verebyinsky ascent, including the bridge, would be causing more and more difficulties. During the same period, it was decided to replace the originally built wooden bridges on the line with metal bridges in order to in-

<sup>6</sup> The successful completion of the Verebyinsky Bridge marked the beginning of Zhuravsky's scientific career and brought him fame as a bridge builder. He published several papers and a monograph *On Howe Truss Bridges*, making an outstanding contribution to construction science. In 1854, the above mentioned paper was submitted for a competition held by the St. Petersburg Academy of Sciences and was awarded the great Demidov Prize in 1855.

<sup>7</sup> Today, the description of the primitive design of manual carriage brakes used until the early 20th century in passenger services and until the 1920s in freight services is a revelation, even for many railway workers, let alone the general public. Thus, the St. Petersburg–Moscow Railway was the first to have one or two conductors (brakemen) onboard each passenger carriage who set the hand brake in motion by the signal (a locomotive whistle) given by the driver. In most designs, they rotated the chain wheel that pressed the wooden brake pads against the set of wheels. Cargo trains included several brake carriages (the number depended on the weight of the train) which had a vestibule where a conductor (brakeman) stayed throughout the journey and operated the brakes at the signal of the locomotive driver.

<sup>8</sup> Horizontal platforms for station tracks began to be built several years later.

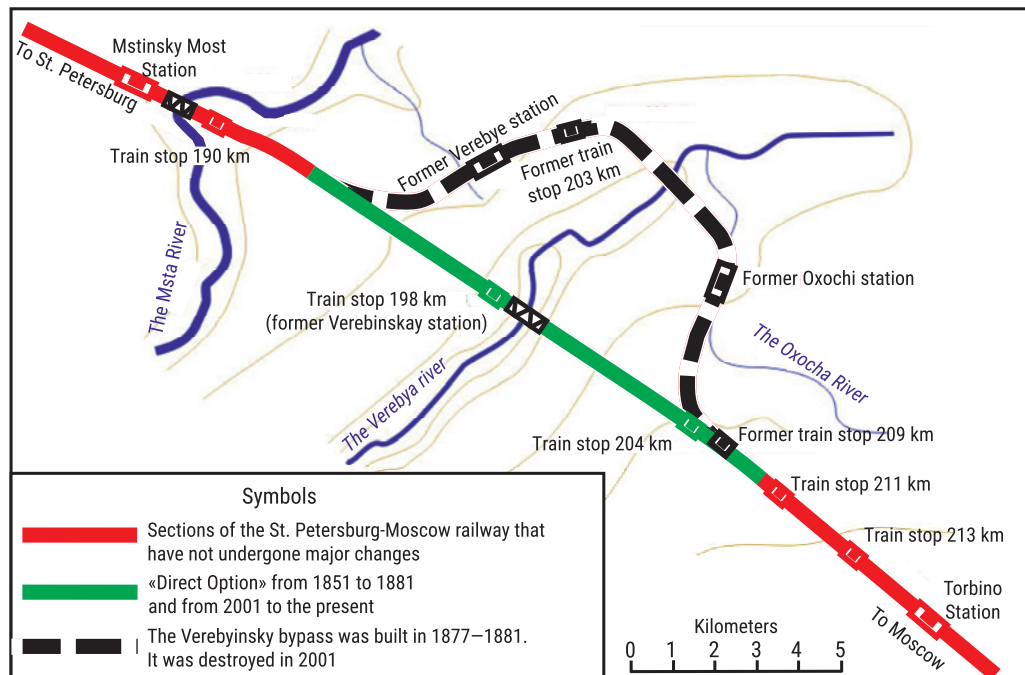

Fig. 6. Verebyinsky bypass scheme. Author: Alexander Fedosov (railway worker). 2008. With supplements by Igor P. Kiselev<sup>9</sup>

crease their load-bearing capacity and improve the carrying capacity of the railway.

The resulting decision provided for a radical solution of the problem of the Verebyinsky ascent and bridge by the comprehensive reconstruction of the railway section, including changes in the horizontal alignment and partial changes in the vertical alignment, which was carried out in 1877–1881.

The surveys carried out in the area of the Msta and Verebya Rivers discovered a good alternative involving building a bypass around the bottleneck with the maximum descents reduced to 6 ‰: the long ascent was divided into several shorter ascents with horizontal sections in between (Fig. 6). In 1878–1880, an embankment about 40 m high with a culvert of about 8 m in diameter was built for the Verebyinsky bypass at the crossing of the Verebye River (Fig. 6) [11]. The work to build the bypass, including construction of man-made structures, was supervised by Nikolai Beleyubsky, an outstanding bridge engineer, Professor of the Institute of Transport Engineers, who also led the design, survey and construction work for replacing the wooden bridges with metal ones [12]. The Verebyinsky bypass was opened on September 14 [26], 1881.

13 small bridges and 12 crossings were built on the bypass. A IV Class station, first named Novo-Verebyinskaya and later named (the former) Verebye station, and a halt station (later Oksochi station) near Oksochi settlement were opened.

The total length of the railway line, including the bypass, was increased by 5.3 km to reach 649.9 km. The new section had 44 % more curve sections, with curves of a smaller radius: 1,065 m (as at operation points) instead of 1,600 m adopted on running lines throughout the railway [7].

The presence of curves of a relatively small (compared to the rest of the St. Petersburg–Moscow line) radius on the new bypass theoretically limited the speed of trains, but in practical terms this was not significant. For a long period of operation, until the first decade of the 20th century, the maximum speed of passenger trains on the St. Petersburg–Moscow line did not exceed 90 km/h. Then, after 1914, the speed was reduced and was increased to 100 km/h in the mid-1950s only, then to 140 km/h in the 1960s, and to 160 km/h in the mid-1960s. [13] Thus, in practical terms, until the 1950s–1960s, the Verebyinsky bypass with its several curved track sections with a radius of 1,065 m did not limit the speed of trains, while after the bypass was complete, the total travel time between the end points increased by approximately 3 or 5 minutes.

The problem of speed limitations to 120–140 km/h on the bypass became relevant in the 1970s–1980s, when high-speed traffic (with a speed of up to 200 km/h) was introduced on the Leningrad–Moscow line [13].

In the early 2000s, as the economic and socio-political situation in Russia improved, it was considered reasonable to gradually introduce high-speed traffic and

<sup>9</sup> URL: <https://dzen.ru/a/ZKaFtH729XQ00KjD>.

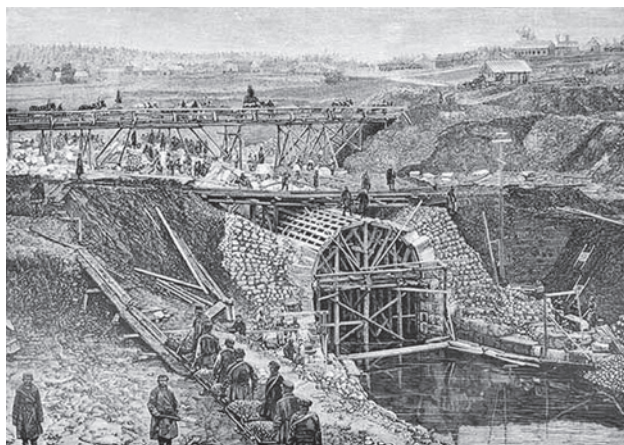

**Fig. 7.** Construction of a culvert on the Verebya River. 1878–1880. Central State Film, Photo and Audio Archives [11]



**Fig. 8.** Modern view of the embankment of the former railway bypass and culvert arch over the Verebya River. Photo by Dmitry Ratnikov. 2023<sup>10</sup>



**Fig. 9.** Construction of the new Verebyinsky Bridge. 2001. Photo by Mikhail Krivykh<sup>11</sup>

purchase foreign rolling stock for the operation on reconstructed lines. In the 2010s, the St. Petersburg–Moscow main line was modernized to accommodate traffic at speeds of up to 250 km/h. Specialists and scientists of Emperor Alexander I St. Petersburg State Transport University (PGUPS) were actively involved in the development of design documentation and scientific support. On a considerable part of the line, the track was rebuilt, including the expansion of the road bed subgrade, making it possible to partially straighten it; the track superstructure was reinforced; switch assemblies were replaced to allow for straight line operation at a speed of over 200 km/h.

The line's power supply system was considerably enhanced and partially redesigned using a new KS250 catenary suspension system developed with the active involvement of scientists at PGUPS [14]. The ICE 3 electric multiple-unit train produced by Siemens, Germany, was chosen by Russian specialists to run on the line. By the early 2000s, it had already proven itself well both in Germany and in Spain and China. A virtually new modification of ICE3, Velaro RUS (Sapsan), was created for the Russian 1,524 mm gauge with account of the clearance standards on Russian railways with the most active participation of the specialists of Russian Railways JSC.

As the line was prepared for accommodating high-speed traffic, practical discussion of the issue of straightening the route by excluding the Verebyinsky bypass started. In 2000, the Ministry of Transport of the Russian Federation decided to abandon the bypass and straighten the railway line along the route that existed before 1881 by building a new bridge across the Verebyinsky ravine (Fig. 7, 8, 9) [15].

In 2001, Mostostroy No. 6 OJSC, a subcontractor of the Baltic Construction Company, completed the construction of a two-track railway bridge crossing over the deep and wide valley of the Verebya River (more than 500 m long and up to 50 m high) for the straightened section at the Verebyinsky bypass on the St. Petersburg–Moscow Railway along the axis of the former wooden railway bridge. Bridge Construction Crews (specialized bridge construction units) No. 37 (St. Petersburg), No. 75 (Veliky Novgorod) and No. 61 (Vologda) of Mostostroy No. 6 OJSC took part in the construction of the bridge abutments [16].

A new double-track railway bridge for traffic at a speed of up to 250 km/h was designed by Giprotransport (a branch of Roszheldorproekt JSC, the state institute for the design of engineering works and industrial enterprises for track facilities and geological surveys) of the Ministry of Railways of the Russian Federation at a

<sup>10</sup> <https://kanoner.com/pics/2023/12/verebynskiy-obhod-arka-vodopropusknoj-truby-nad-rekoj-verebe.jpg>

<sup>11</sup> URL: <https://news.novgorod.ru/articles/read/475.html>



**Fig. 10.** New Verebyinsky Bridge with a running Sapsan train. 2001. Photo by Mikhail Krivykh<sup>12</sup>

slope of about 5 ‰ following the 9×55 metre scheme with metal split superstructures according to standard design 739/7 by Giprotransmost (the state design and survey institute for the design of bridges) for traveling on top of the precast reinforced concrete slabs of the ballast tank.

The steel and reinforced concrete split superstructures with 55 m spans built to standard design 739/7 of Giprotransmost had deck plate girders. The main 3.6 m girders consist of three blocks (17 + 21 + 17 m) [16].

The construction of the bridge involved driving and ramming about 2,000 metres of reinforced concrete piles; laying 11,000 metres of concrete and reinforced concrete masonry in the abutments; fabricating and installing 2,700 tonnes of metal structures for the superstructures; fabricating and installing 560 tonnes of metal formwork for the reinforced concrete slabs of the ballast tank; fabricating and installing 1,860 metres of reinforced concrete slab units; fabricating and installing more than 500 tonnes of auxiliary structures [16].

The new 536 m long and 53 m high bridge was opened for traffic on October 26, 2001. 17 km of the track superstructure of the former railway bypass and the Oksochi and Verebye stations located on it were dismantled by 2008. At the same time, the kilometre markers on the route from St. Petersburg to Moscow (and the sites of the distance markers colloquially known as “kilometre posts”) that had been determined

after the completion of the Verebyinsky bypass in 1881 extending the line to 649.9 km were left unchanged. Thus, in the area of the former Verebyinsky bypass, the “205” kilometre post is followed by the “211” marker.

Commercial operation of Sapsan trains on the Moscow–St. Petersburg line began on December 17, 2009. The operation was serviced by three pairs of trains per day. The route soon became very popular with passengers [13].

The creation a new specialized high-speed railway line between St. Petersburg and Moscow parallel to the railway opened in 1851 has been discussed since 1988, when the State Science and Technology Programme “High-speed Railway Transport”<sup>13</sup> was introduced.

Over the past years, the question has been considered at several levels. A feasibility study for the project was prepared; a relevant legal framework was developed; design and survey work and some detailed engineering activities started; and a pilot high-speed train Sokol was created. In a test trip on July 29, 2001, the train achieved the speed of 236 km/h, which was a record at the time for Russia; however, no large-scale production of the train was launched because of the economic situation.

The implementation of the project was set aside because of the complicated and contradictory socio-economic and political landscape in Russia in the late 1990s. The idea of high-speed railway traffic between the two largest cities, the two capitals of the Russian

<sup>12</sup> URL: <https://news.novgorod.ru/articles/read/475.html>

<sup>13</sup> The State Science and Technology Programme “High-Speed Environmentally Friendly Transport” was approved by Decree of the Council of Ministers of the USSR No. 1474 dated December 30, 1988 [17].

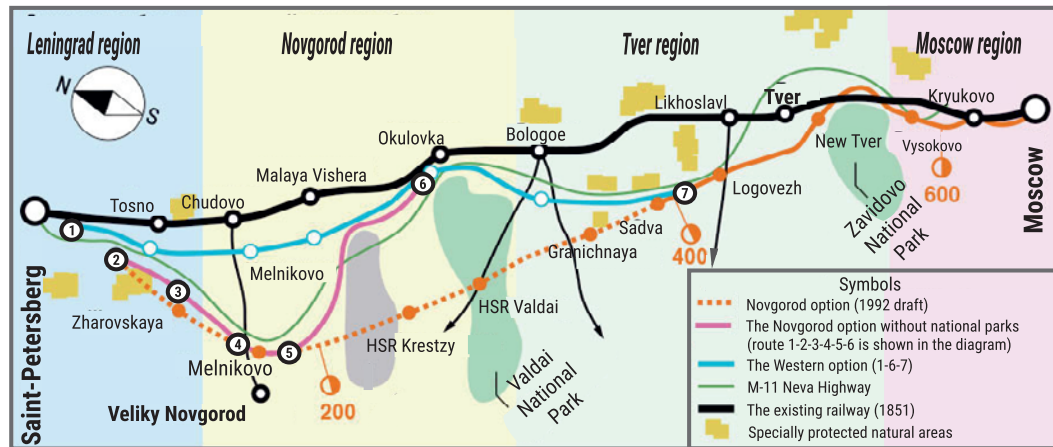

Fig. 11. Alternative routes of the Moscow–St. Petersburg HSR // Science and Transport, Annual Supplement to the *Transport of the Russian Federation Journal*. 2009. P. 10

Federation, was revisited at the end of the first decade of the 2000s.

On April 10, 2020, Russian President Vladimir Putin ordered to start designing the Moscow–St. Petersburg HSR. On September 29, 2021, the Moscow–St. Petersburg HSR was included in the Land-Use Planning Scheme of the Russian Federation for the Development of Federal (Railway, Air, Sea, and Inland Water) Transport and Federal Roads.

On August 17, 2023, President Vladimir Putin approved the National Project “Development of High-speed Railways” (HSR) and its first stage, the Moscow–St. Petersburg HSR Project [18]. Design and survey, engineering and preparation work for the creation of Russia’s first HSR are underway.

More than 170 years after the launch of the St. Petersburg–Moscow Railway, the situation in its adjacent areas, populated localities, railway stations and the right-of-way along the railway line has changed drastically. Figuratively speaking, it has been “overgrown” with tracks, railway depots, station buildings, warehouses, and industrial facilities; lots of residential buildings have been built immediately adjacent to the railway and the grounds of stations; villages and towns have grown nearby.

The current attempts to lay the HSR route along the existing railway inevitably lead to considerable deviations from the longitudinal axis of its tracks. It is necessary to bypass railway station tracks and buildings in the right-of-way of the railway. Theoretically, it is possible to lay the new high-speed railway on the second level on continuous elevated structures with placing the supports near the existing tracks. But this increases construction costs significantly compared to the green-field construction of a new railway. It will be necessary to build the elevated structures above the operational railway tracks with heavy traffic, “under the wheels of running trains” to put it figuratively.

In addition, various facilities where construction work is prohibited are located along the proposed line of the new HSR, such as, for example, dozens of specially protected natural areas (reserves), including one of the largest in Russia, the Valdai National Park. Many of these specially protected areas were identified and placed under protection (turned into reserves) in the 20th century and as such were not taken into account in the mid-19th century when the St. Petersburg–Moscow was built.

The design work on the St. Petersburg–Moscow HSR in the 1990s has shown that the new line’s route will need to be moved away from the existing railway in order to bypass the emerging obstacles with the least losses and costs possible (Fig. 11). For example, the satisfactory alternative designed in the 1990s turned out to be 659.1 km long [19], i.e. 14.8 km longer than the existing railway line. The front-end engineering design in the 2020s (the so-called “Novgorod alternative” bypassing the specially protected natural areas) has shown that the length of the route will be about 679 km [5], because the situation along the railway has substantially changed over the past 30 years.

## CONCLUSION

The parameters set for a number of railway lines built in the 19th century, such as vertical and horizontal alignments, route development ratio, minimum horizontal and vertical curve radii, still remain relevant in the 21st century. The St. Petersburg–Moscow Railway in Russia put into operation in 1851 is a compelling example. The modernization efforts completed during the period of its operation, including electrification and enhancement of its technical facilities, without affecting the basic parameters of the line allowed for launching high-speed traffic at speeds of up to 250 km/h with

the use of modern rolling stock. At the same time, we can conclude that the construction of new high-speed railways in the world, both using the conventional “wheel/rail” method and the advanced magnetic suspension (maglev) technology, will face the phenomenon illustrated by the case of the St. Petersburg–Moscow Railway. It will be necessary to extend the railway route compared to the existing conventional railways

and, in the future, even to high-speed railways built earlier. We need to revise the ideas about the quality criteria for design and survey activities that have been in place for nearly two centuries by taking into account the route development (elongation) ratio. We can confidently conclude that in many cases this ratio is worse for advanced high-speed railways than for the existing railways.

## REFERENCES

1. Bogdanov A.I. *Surveying and designing railways*. Moscow. Yurait. 2025:104 p. URL: <https://urait.ru/bcode/568584>. (In Russ.).
2. *Construction and operation of the Nikolaev railway (1842–1851–1901): Brief historical essay. Compiled by the road administration*. St. Petersburg. Erlich Printing House. 1901:65. (In Russ.).
3. *History of railway transport in Russia*. In 3 volumes. Vol. 1: 1836–1917. Edited by E.Ya. Kraskovsky, M.M. Uzdin. St. Petersburg; Moscow. 1994:335. (In Russ.).
4. Rakcheev E.N. *Dmitry Ivanovich Zhuravsky, 1821–1891*. Moscow. Nauka. 1984:240. (In Russ.).
5. *The most famous railway workers of Russia*. Compiled by T.L. Pashkova, V.A. Mikhailov. Moscow. Veche. 2005:316. (In Russ.).
6. Krivykh M. Verebynsky Bridge: grandiose structures of the Novgorod region. *Novgorod.ru*. 01.22.2015. URL: <https://news.novgorod.ru/articles/read/475.html>. (In Russ.).
7. Kiselev I.P. Bridge to the Future // *Problems of Strength of Materials and Structures in Transport Construction: International Scientific and Practical Conference Dedicated to the 175th Anniversary of the Birth of Professor N.A. Belelyubsky, St. Petersburg, May 18–20, 2021*. St. Petersburg: Emperor Alexander I Petersburg State University of Railway Engineering, 2021:6-15. EDN MQYNMF. (In Russ.).
8. Valinsky O.S., Kiselev I.P. Scientific support for the design and construction of high-speed railway lines. *Transport of the Russian Federation. Journal of science, practice, economics*. 2024;1(110):11-28. EDN AKBQLP. (In Russ.).
9. Konovalova N., Kutsenina T., Retyunin A., Yurinov V. *From Estonia 200 to Sapsan*. St. Petersburg: OM-Express, 2023. 288 p. (In Russ.).
10. Turchenko V., Kharebov S. Verebinsky bypass (abandoned legend). *Semafor*. 2023. Issue 5. URL: [https://semafor.narod.ru/5\\_2003/vereb.html](https://semafor.narod.ru/5_2003/vereb.html). (In Russ.).
11. Shapiro L.B., Surovtsev A.B., Mukharev A.A. Bridge crossing over the Verebye River // JSC Institute Giprotransmost St. Petersburg. URL: <https://gpsm.narod.ru/Projects/Verebye.htm>. (In Russ.).
12. *High-speed rail transport. General course: Textbook for students of higher education institutions of railway transport*: I.P. Kiselev, L.S. Blazhko, M.Ya. Bryn [et al.]; edited by I.P. Kiselev. Moscow: Federal State Budgetary Institution of Continuing Professional Education “Educational and Methodological Center for Education in Railway Transport”. 2020:428 p. EDN MPVRST. (In Russ.).
13. Chronology of events. High-speed railway Two capitals. Concessionaire company for the project to build the high-speed railway Moscow – St. Petersburg. *High-speed railway. High-speed railway. Project of the President of the Russian Federation*. URL: <https://xn--2-edd7ardtwe15cxd.xn--p1ai/#contacts>. (In Russ.).
14. Alimov A.F. et al. *High-speed and high-speed rail transport: In the past, present and future: On the 150th anniversary of the St. Petersburg-Moscow railway*. 2003:447 p. EDN QNQGUX. (In Russ.).
15. Serebryakov D. What is known about the Moscow-St. Petersburg high-speed railway. *Information Telegraph Agency of Russia (ITAR-TASS)*. 12.23.2024. URL: <https://tass.ru/info/20230979>. (In Russ.).

## ЛИТЕРАТУРА

1. *Богданов А.И. Изыскания и проектирование железных дорог : учебник для вузов*. М.: Юрайт, 2025. 104 с. (Высшее образование). URL: <https://urait.ru/bcode/568584>.
2. *Постройка и эксплуатация Николаевской железной дороги (1842 – 1851 – 1901 гг.): Краткий исторический очерк / Составлен управлением дороги*. СПб.: Тип. Эрлихъ, 1901. 65 с.
3. *История железнодорожного транспорта России*. В 3 т. Т. 1: 1836–1917 / под ред. Е.Я. Красковского, М.М. Уздина. СПб.; М., 1994. 335 с.
4. *Ракчеев Е.Н. Дмитрий Иванович Журавский, 1821–1891*. М.: Наука, 1984. 240 с. : ил. (Научно-биографическая серия).
5. *Самые знаменитые железнодорожники России / сост. Т.Л. Пашкова, В.А. Михайлов*. М.: Вече, 2005. 316 с.: ил.
6. *Кривых М. Веребынский мост: грандиозные сооружения Новгородской области // Novgorod.ru*. 22.01.2015. URL: <https://news.novgorod.ru/articles/read/475.html>.
7. *Киселев И.П. Мост в будущее // Проблемы прочности материалов и конструкций в транспортном строительстве : Международная научно-практическая конференция, посвященная 175-летию со дня рождения профессора Н.А. Белелюбского, Санкт-Петербург, 18–20 мая 2021 года*. Санкт-Петербург: Петербургский государственный университет путей сообщения Императора Александра I, 2021. С. 6–15. EDN MQYNMF.
8. *Валинский О.С., Киселев И.П. Научное обеспечение проектирования и строительства высокоскоростных железно-*

дорожных магистралей // Транспорт Российской Федерации. Журнал о науке, практике, экономике. 2024. № 1(110). С. 11–28. EDN AKBQLP.

9. Коновалова Н., Куценина Т., Ретюнин А., Юринов В. От ЭР200 до «Сапсана». СПб.: ОМ-Экспресс, 2023. 288 с.

10. Турченко В., Харемов С. Веребьнский обход (заброшенная легенда). Семафор. 2023. Вып. 5. URL: [https://semafor.narod.ru/5\\_2003/vereb.html](https://semafor.narod.ru/5_2003/vereb.html).

11. Шапиро Л.Б., Суворцев А.Б., Мухарев А.А. Мостовой переход через реку Веребью // ОАО «Институт Гипротрансмост Санкт-Петербург». URL: <https://gpsm.narod.ru/Projects/Verebye.htm>.

12. Высокоскоростной железнодорожный транспорт. Общий курс: Учебное пособие для студентов вузов железнодорожного транспорта: в 2 т. / И.П. Киселев, Л.С. Блажко, М.Я. Брынь [и др.]; под ред. И.П. Киселева. Т. 1. 2-е изд., пере-

раб. и доп. М.: Федеральное государственное бюджетное учреждение дополнительного профессионального образования «Учебно-методический центр по образованию на железнодорожном транспорте», 2020. 428 с. EDN MPVRST.

13. Хронология событий. ВСМ Две столицы. Компания концессионер проекта строительства высокоскоростной железнодорожной магистрали Москва – Санкт-Петербург // ВСМ. Высокоскоростная магистраль. Проект Президента РФ. URL: <https://xn--2-edd7ardtwel5cxd.xn--p1ai/#contacts>.

14. Скоростной и высокоскоростной железнодорожный транспорт : В прошлом, настоящем и будущем : К 150-летию железнодорож. магистрали Санкт-Петербург – Москва / А.Ф. Алимов [и др. [Б.м.], 2003. 447 с. EDN QNQGUX.

15. Серебряков Д. Что известно о ВСМ Москва – Санкт-Петербург // Информационное телеграфное агентство России (ИТАР-ТАСС), 23.12.2024. URL: <https://tass.ru/info/20230979>.

## Bionotes

**Igor P. Kiselev** — Cand. Sci. (Philos.), Dr. Sci. (His.), Professor of the Department of “History, Philosophy, Political Science and Sociology”, transport engineer; **Emperor Alexander I St. Petersburg State Transport University (PGUPS)**; 9 Moskovsky pr., St. Petersburg, 190031, Russian Federation; Chief Science Editor; **Journal “BRICS Transport”**; SPIN-code: 4347-9926, ID RSCI: 541415, Scopus: 57220864567; [kis1347@mail.ru](mailto:kis1347@mail.ru).

## Об авторе

**Игорь Павлович Киселев** — кандидат философских наук, доктор исторических наук, профессор кафедры «История, философия, политология и социология», инженер путей сообщения; **Петербургский государственный университет путей сообщения Императора Александра I (ПГУПС)**; 190031, г. Санкт-Петербург, Московский пр., д. 9; главный научный редактор; журнал «Транспорт БРИКС»; SPIN-код: 4347-9926, РИНЦ ID: 541415, Scopus: 57220864567; [kis1347@mail.ru](mailto:kis1347@mail.ru).

The author declares no conflicts of interests.

Автор заявляет об отсутствии конфликта интересов.

The article was submitted 16.07.2025; accepted for publication 28.08.2025.

Статья поступила в редакцию 16.07.2025; принята к публикации 28.08.2025.